



TECHNICAL EDUCATION AND SKILLS DEVELOPMENT AUTHORITY (TESDA)

# **BID DOCUMENTS**

**Procurement of CMU  
Boxes, Tools and  
Equipment and Mock-  
ups for the Mobile  
Training Laboratories  
(MTLs) – Re-Bidding of  
Lots 1 to 8**

2016-11

*Handwritten signature/initials*

# TABLE OF CONTENTS

SECTION I. INVITATION TO BID .....	2
SECTION II. INSTRUCTIONS TO BIDDERS.....	3
SECTION III. BID DATA SHEET .....	31
SECTION IV. GENERAL CONDITIONS OF CONTRACT.....	35
SECTION V. SPECIAL CONDITIONS OF CONTRACT.....	51
SECTION VI. SCHEDULE OF REQUIREMENTS .....	58
SECTION VII. TECHNICAL SPECIFICATIONS .....	59
SECTION VIII. BIDDING FORMS .....	60

*Handwritten initials:*  
JL  
atb

# ***Section I. Invitation to Bid***

✓  
at  
let



TECHNICAL EDUCATION AND SKILLS DEVELOPMENT AUTHORITY

ISO 9001 : 2008 CERTIFIED

Tatak ng Integridad, Serbisyong Dekalidad, Kaagapay sa Pag-unlad



INVITATION TO BID

The Technical Education and Skills Development Authority (TESDA), through the TESDA Trust Fund Account, intends to apply the sum of Six Million One Hundred Fifty-Four Thousand Nine Hundred Sixteen Pesos and 05/100 (Php6,154,916.05) being the Approved Budget for the Contract (ABC), to payment for Procurement of CMU Boxes, Tools and Equipment and Mock-ups for the Mobile Training Laboratories (MTLs) - Rebidding of Lots 1 to 8. Bids received in excess of the ABC shall be automatically rejected at the bid opening.

TESDA now invites suppliers to apply for eligibility and to bid for Procurement of CMU Boxes, Tools and Equipment and Mock-ups for the Mobile Training Laboratories (MTLs) - Rebidding of Lots 1 to 8.

Bidders must have completed at least one (1) contract that is similar to the contract to be bid within five (5) year period from the date of the bid opening and whose value must be at least fifty percent (50%) of the ABC. The description of an eligible bidder is contained in the Bidding Documents, particularly in Section II of the Instructions to Bidders.

Bidding will be conducted through public bidding using a non-discretionary "pass/fail" criterion as prescribed by the Revised Implementing Rules and Regulations (RIRR) of Republic Act No. 9184, otherwise known as the Government Procurement Reform Act.

Only bids for all the items in each lot shall be accepted by the Procuring Entity.

A complete set of Bidding Documents may be purchased by interested Bidders beginning on 13 October 2016 from the address written below and upon payment of a non-refundable fee relative to the cost of the Bidding Documents which shall be based on the following standard rates:

Approved Budget for the Contract	Maximum Cost of Bidding Documents (in Philippine Peso)
500,000 and below	500.00
More than 500,000 up to 1 Million	1,000.00
More than 1 Million up to 5 Million	5,000.00
More than 5 Million up to 10 Million	10,000.00
More than 10 Million up to 50 Million	25,000.00
More than 50 Million up to 500 Million	50,000.00
More than 500 Million	75,000.00

The amount of the Bidding Documents shall depend on the ABC of the lot/s that will be participated in by the prospective Bidder. At any rate, the standard rates as provided by the Government Procurement Policy Board (GPPB) shall apply.

7

TESDA will hold a Pre-Bid Conference on **21 October 2016, 2:00 p.m.** at the CSA Conference Room, 2<sup>nd</sup> Floor, TESDA Administration Building, Taguig City, which shall be open to all interested parties who have purchased the Bidding Documents.

Bids must be submitted to the BAC Secretariat, CSA Conference Room, 2<sup>nd</sup> Floor, TESDA Administration Building, Taguig City, on or before **08 November 2016 at 10:00 a.m.** All bids must be accompanied by a bid security in any of the acceptable forms and in the amount stated in Clause 18 of Instructions to Bidders.

Bid opening shall be held on **08 November 2016 at 10:15 a.m.** at the CSA Conference Room, 2<sup>nd</sup> Floor, TESDA Administration Building, Taguig City where the bids will be opened in the presence of the Bidders' representatives. Late bids shall not be accepted.

All particulars relative to the Eligibility Statement and Screening, Bid Security, Performance Security, Pre-Bid Conference, Evaluation of Bids, Post-Qualification and Award of Contract shall be governed by the pertinent provisions of Republic Act No. 9184 and its Revised Implementing Rules and Regulations.

TESDA reserves the right to accept or reject any bid, to annul the bidding process, and to reject all bids at any time prior to award of contract, without thereby incurring any liability to the affected bidder or bidders.

TESDA assumes no responsibility whatsoever to compensate or indemnify bidders for any expenses incurred in the preparation of their bids.

For further information, please refer to:

BAC Secretariat  
3<sup>rd</sup> Floor, Procurement Division  
TESDA Administration Building  
South Luzon Expressway, Taguig City  
Telefax: (02) 893-8296

  
**ATTY. DIOSDADO O. PADILLA**  
Chairperson, Bids and Awards Committee

↑

# *Section II. Instructions to Bidders*

## TABLE OF CONTENTS

A. GENERAL.....	5
1. Scope of Bid.....	5
2. Source of Funds.....	5
3. Corrupt, Fraudulent, Collusive, and Coercive Practices.....	5
4. Conflict of Interest.....	6
5. Eligible Bidders.....	8
6. Bidder's Responsibilities.....	9
7. Origin of Goods.....	10
8. Subcontracts.....	11
B. CONTENTS OF BIDDING DOCUMENTS.....	11
9. Pre-Bid Conference.....	11
10. Clarification and Amendment of Bidding Documents.....	12
C. PREPARATION OF BIDS.....	12
11. Language of Bid.....	12
12. Documents Comprising the Bid: Eligibility and Technical Components.....	12
13. Documents Comprising the Bid: Financial Component.....	14
14. Alternative Bids.....	15
15. Bid Prices.....	15
16. Bid Currencies.....	17
17. Bid Validity.....	17
18. Bid Security.....	17
19. Format and Signing of Bids.....	20
20. Sealing and Marking of Bids.....	20
D. SUBMISSION AND OPENING OF BIDS.....	21
21. Deadline for Submission of Bids.....	21
22. Late Bids.....	21
23. Modification and Withdrawal of Bids.....	21
24. Opening and Preliminary Examination of Bids.....	22
E. EVALUATION AND COMPARISON OF BIDS.....	23
25. Process to be Confidential.....	23

26.	Clarification of Bids .....	23
27.	Domestic Preference .....	23
28.	Detailed Evaluation and Comparison of Bids .....	24
29.	Post-Qualification.....	25
30.	Reservation Clause .....	26
F.	AWARD OF CONTRACT .....	27
31.	Contract Award .....	27
32.	Signing of the Contract .....	28
33.	Performance Security .....	29
34.	Notice to Proceed .....	30

*Handwritten initials/signature*

## A. General

### 1. Scope of Bid

- 1.1. The procuring entity named in the **BDS** (hereinafter referred to as the "Procuring Entity") wishes to receive bids for supply and delivery of the goods as described in Section VII. Technical Specifications (hereinafter referred to as the "Goods").
- 1.2. The name, identification, and number of lots specific to this bidding are provided in the **BDS**. The contracting strategy and basis of evaluation of lots is described in ITB Clause 28.

### 2. Source of Funds

The Procuring Entity has a budget or has applied for or received funds from the Funding Source named in the **BDS**, and in the amount indicated in the **BDS**. It intends to apply part of the funds received for the Project, as defined in the **BDS**, to cover eligible payments under the contract.

### 3. Corrupt, Fraudulent, Collusive, and Coercive Practices

- 3.1. Unless otherwise specified in the **BDS**, the Procuring Entity as well as the bidders and suppliers shall observe the highest standard of ethics during the procurement and execution of the contract. In pursuance of this policy, the Procuring Entity:
  - (a) defines, for purposes of this provision, the terms set forth below as follows:
    - (i) "corrupt practice" means behavior on the part of officials in the public or private sectors by which they improperly and unlawfully enrich themselves, others, or induce others to do so, by misusing the position in which they are placed, and includes the offering, giving, receiving, or soliciting of anything of value to influence the action of any such official in the procurement process or in contract execution; entering, on behalf of the government, into any contract or transaction manifestly and grossly disadvantageous to the same, whether or not the public officer profited or will profit thereby, and similar acts as provided in RA 3019.
    - (ii) "fraudulent practice" means a misrepresentation of facts in order to influence a procurement process or the execution of a contract to the detriment of the Procuring Entity, and includes collusive practices among Bidders (prior to or after bid submission) designed to establish bid prices at artificial, non-competitive levels and to deprive the Procuring Entity of the benefits of free and open competition.



- (iii) "collusive practices" means a scheme or arrangement between two or more Bidders, with or without the knowledge of the Procuring Entity, designed to establish bid prices at artificial, non-competitive levels.
  - (iv) "coercive practices" means harming or threatening to harm, directly or indirectly, persons, or their property to influence their participation in a procurement process, or affect the execution of a contract;
  - (v) "obstructive practice" is
    - (aa) deliberately destroying, falsifying, altering or concealing of evidence material to an administrative proceedings or investigation or making false statements to investigators in order to materially impede an administrative proceedings or investigation of the Procuring Entity or any foreign government/foreign or international financing institution into allegations of a corrupt, fraudulent, coercive or collusive practice; and/or threatening, harassing or intimidating any party to prevent it from disclosing its knowledge of matters relevant to the administrative proceedings or investigation or from pursuing such proceedings or investigation; or
    - (bb) acts intended to materially impede the exercise of the inspection and audit rights of the Procuring Entity or any foreign government/foreign or international financing institution herein.
- (b) will reject a proposal for award if it determines that the Bidder recommended for award has engaged in any of the practices mentioned in this Clause for purposes of competing for the contract.

3.2. Further, the Procuring Entity will seek to impose the maximum civil, administrative, and/or criminal penalties available under applicable laws on individuals and organizations deemed to be involved in any of the practices mentioned in ITB Clause 3.1(a).

3.3. Furthermore, the Funding Source and the Procuring Entity reserve the right to inspect and audit records and accounts of a bidder or supplier in the bidding for and performance of a contract themselves or through independent auditors as reflected in the GCC Clause 3.

#### 4. Conflict of Interest

4.1. All Bidders found to have conflicting interests shall be disqualified to participate in the procurement at hand, without prejudice to the imposition of appropriate administrative, civil, and criminal sanctions. A Bidder may be considered to have conflicting interests with another Bidder in any of the

events described in paragraphs (a) through (c) below and a general conflict of interest in any of the circumstances set out in paragraphs (d) through (f) below:

- (a) A Bidder has controlling shareholders in common with another Bidder;
- (b) A Bidder receives or has received any direct or indirect subsidy from any other Bidder;
- (c) A Bidder has the same legal representative as that of another Bidder for purposes of this bid;
- (d) A Bidder has a relationship, directly or through third parties, that puts them in a position to have access to information about or influence on the bid of another Bidder or influence the decisions of the Procuring Entity regarding this bidding process. This will include a firm or an organization who lends, or temporarily seconds, its personnel to firms or organizations which are engaged in consulting services for the preparation related to procurement for or implementation of the project if the personnel would be involved in any capacity on the same project;
- (e) A Bidder submits more than one bid in this bidding process. However, this does not limit the participation of subcontractors in more than one bid; or
- (f) A Bidder who participated as a consultant in the preparation of the design or technical specifications of the Goods and related services that are the subject of the bid.

4.2. In accordance with Section 47 of the IRR of RA 9184, all Bidding Documents shall be accompanied by a sworn affidavit of the Bidder that it is not related to the Head of the Procuring Entity, members of the Bids and Awards Committee (BAC), members of the Technical Working Group (TWG), members of the BAC Secretariat, the head of the Project Management Office (PMO) or the end-user unit, and the project consultants, by consanguinity or affinity up to the third civil degree. On the part of the Bidder, this Clause shall apply to the following persons:

- (a) If the Bidder is an individual or a sole proprietorship, to the Bidder himself;
- (b) If the Bidder is a partnership, to all its officers and members;
- (c) If the Bidder is a corporation, to all its officers, directors, and controlling stockholders; and
- (d) If the Bidder is a joint venture (JV), the provisions of items (a), (b), or (c) of this Clause shall correspondingly apply to each of the members of the said JV, as may be appropriate.

Relationship of the nature described above or failure to comply with this Clause will result in the automatic disqualification of a Bidder.

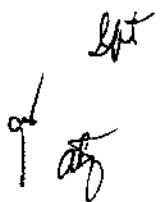
Handwritten initials and a signature in the bottom right corner of the page.

## 5. Eligible Bidders

- 5.1. Unless otherwise provided in the **BDS**, the following persons shall be eligible to participate in this bidding:
- (a) Duly licensed Filipino citizens/sole proprietorships;
  - (b) Partnerships duly organized under the laws of the Philippines and of which at least sixty percent (60%) of the interest belongs to citizens of the Philippines;
  - (c) Corporations duly organized under the laws of the Philippines, and of which at least sixty percent (60%) of the outstanding capital stock belongs to citizens of the Philippines;
  - (d) Cooperatives duly organized under the laws of the Philippines, and of which at least sixty percent (60%) of the interest belongs to citizens of the Philippines; and
  - (e) Unless otherwise provided in the **BDS**, persons/entities forming themselves into a JV, *i.e.*, a group of two (2) or more persons/entities that intend to be jointly and severally responsible or liable for a particular contract: Provided, however, that Filipino ownership or interest of the joint venture concerned shall be at least sixty percent (60%).
- 5.2. Foreign bidders may be eligible to participate when any of the following circumstances exist, as specified in the **BDS**:
- (a) When a Treaty or International or Executive Agreement as provided in Section 4 of the RA 9184 and its IRR allow foreign bidders to participate;
  - (b) Citizens, corporations, or associations of a country, included in the list issued by the GPPB, the laws or regulations of which grant reciprocal rights or privileges to citizens, corporations, or associations of the Philippines;
  - (c) When the Goods sought to be procured are not available from local suppliers; or
  - (d) When there is a need to prevent situations that defeat competition or restrain trade.
- 5.3. Government corporate entities may be eligible to participate only if they can establish that they (a) are legally and financially autonomous, (b) operate under commercial law, and (c) are not dependent agencies of the GOP or the Procuring Entity.
- 5.4. Unless otherwise provided in the **BDS**, the Bidder must have completed at least one contract similar to the Project the value of which, adjusted to current

prices using the National Statistics Office consumer price index, must be at least equivalent to a percentage of the ABC stated in the **BDS**.

For this purpose, contracts similar to the Project shall be those described in the **BDS**, and completed within the relevant period stated in the Invitation to Bid and ITB Clause 12.1(a)(iii).

- 5.5. The Bidder must submit a computation of its Net Financial Contracting Capacity (NFCC), which must be at least equal to the ABC to be bid, calculated as follows:

NFCC = [(Current assets minus current liabilities) (K)] minus the value of all outstanding or uncompleted portions of the projects under ongoing contracts, including awarded contracts yet to be started coinciding with the contract for this Project.

Where:

K = 10 for a contract duration of one year or less, 15 for a contract duration of more than one year up to two years, and 20 for a contract duration of more than two years.

The values of the bidder's current assets and current liabilities shall be based on the data submitted to the BIR, through its Electronic Filing and Payment System (EFPS).

## 6. Bidder's Responsibilities

- 6.1. The Bidder or its duly authorized representative shall submit a sworn statement in the form prescribed in Section VIII. Bidding Forms as required in ITB Clause 12.1(b)(iii).
- 6.2. The Bidder is responsible for the following:
- (a) Having taken steps to carefully examine all of the Bidding Documents;
  - (b) Having acknowledged all conditions, local or otherwise, affecting the implementation of the contract;
  - (c) Having made an estimate of the facilities available and needed for the contract to be bid, if any;
  - (d) Having complied with its responsibility to inquire or secure Supplemental/Bid Bulletin(s) as provided under ITB Clause 10.3.
  - (e) Ensuring that it is not "blacklisted" or barred from bidding by the GOP or any of its agencies, offices, corporations, or LGUs, including foreign government/foreign or international financing institution whose blacklisting rules have been recognized by the GPPB;

- (f) Ensuring that each of the documents submitted in satisfaction of the bidding requirements is an authentic copy of the original, complete, and all statements and information provided therein are true and correct;
- (g) Authorizing the Head of the Procuring Entity or its duly authorized representative/s to verify all the documents submitted;
- (h) Ensuring that the signatory is the duly authorized representative of the Bidder, and granted full power and authority to do, execute and perform any and all acts necessary and/or to represent the Bidder in the bidding, with the duly notarized Secretary's Certificate attesting to such fact, if the Bidder is a corporation, partnership, cooperative, or joint venture;
- (i) Complying with the disclosure provision under Section 47 of RA 9184 in relation to other provisions of RA 3019; and
- (j) Complying with existing labor laws and standards, in the case of procurement of services.

Failure to observe any of the above responsibilities shall be at the risk of the Bidder concerned.

- 6.3. The Bidder is expected to examine all instructions, forms, terms, and specifications in the Bidding Documents.
- 6.4. It shall be the sole responsibility of the Bidder to determine and to satisfy itself by such means as it considers necessary or desirable as to all matters pertaining to the contract to be bid, including: (a) the location and the nature of this Project; (b) climatic conditions; (c) transportation facilities; and (d) other factors that may affect the cost, duration, and execution or implementation of this Project.
- 6.5. The Procuring Entity shall not assume any responsibility regarding erroneous interpretations or conclusions by the prospective or eligible bidder out of the data furnished by the procuring entity.
- 6.6. The Bidder shall bear all costs associated with the preparation and submission of his bid, and the Procuring Entity will in no case be responsible or liable for those costs, regardless of the conduct or outcome of the bidding process.
- 6.7. Before submitting their bids, the Bidder is deemed to have become familiar with all existing laws, decrees, ordinances, acts and regulations of the Philippines which may affect this Project in any way.
- 6.8. The Bidder should note that the Procuring Entity will accept bids only from those that have paid the nonrefundable fee for the Bidding Documents at the office indicated in the Invitation to Bid.

## 7. Origin of Goods

Unless otherwise indicated in the **BDS**, there is no restriction on the origin of goods other than those prohibited by a decision of the United Nations Security Council taken under Chapter VII of the Charter of the United Nations, subject to **ITB Clause 27.1**.

## **8. Subcontracts**

- 8.1. Unless otherwise specified in the **BDS**, the Bidder may subcontract portions of the Goods to an extent as may be approved by the Procuring Entity and stated in the **BDS**. However, subcontracting of any portion shall not relieve the Bidder from any liability or obligation that may arise from the contract for this Project.
- 8.2. Subcontractors must comply with the eligibility criteria and the documentary requirements specified in the **BDS**. In the event that any subcontractor is found by the Procuring Entity to be ineligible, the subcontracting of such portion of the Goods shall be disallowed.
- 8.3. The Bidder may identify the subcontractor to whom a portion of the Goods will be subcontracted at any stage of the bidding process or during contract implementation. If the Bidder opts to disclose the name of the subcontractor during bid submission, the Bidder shall include the required documents as part of the technical component of its bid.

## **B. Contents of Bidding Documents**

### **9. Pre-Bid Conference**

- 9.1. (a) If so specified in the **BDS**, a pre-bid conference shall be held at the venue and on the date indicated therein, to clarify and address the Bidders' questions on the technical and financial components of this Project.  
  
*(b) The pre-bid conference shall be held at least twelve (12) calendar days before the deadline for the submission and receipt of bids. If the Procuring Entity determines that, by reason of the method, nature, or complexity of the contract to be bid, or when international participation will be more advantageous to the GOP, a longer period for the preparation of bids is necessary, the pre-bid conference shall be held at least thirty (30) calendar days before the deadline for the submission and receipt of bids, as specified in the **BDS**.*
- 9.2. Bidders are encouraged to attend the pre-bid conference to ensure that they fully understand the Procuring Entity's requirements. Non-attendance of the Bidder will in no way prejudice its bid; however, the Bidder is expected to know the changes and/or amendments to the Bidding Documents discussed during the pre-bid conference.
- 9.3. Any statement made at the pre-bid conference shall not modify the terms of the Bidding Documents unless such statement is specifically identified in writing as an amendment thereto and issued as a Supplemental/Bid Bulletin.

## 10. Clarification and Amendment of Bidding Documents

- 10.1. Bidders who have purchased the Bidding Documents may request for clarification on any part of the Bidding Documents for an interpretation. Such request must be in writing and submitted to the Procuring Entity at the address indicated in the **BDS** at least ten (10) calendar days before the deadline set for the submission and receipt of bids.
- 10.2. Supplemental/Bid Bulletins may be issued upon the Procuring Entity's initiative for purposes of clarifying or modifying any provision of the Bidding Documents not later than seven (7) calendar days before the deadline for the submission and receipt of bids. Any modification to the Bidding Documents shall be identified as an amendment.
- 10.3. Any Supplemental/Bid Bulletin issued by the BAC shall also be posted on the Philippine Government Electronic Procurement System (PhilGEPS) and the website of the Procuring Entity concerned, if available. It shall be the responsibility of all Bidders who secure the Bidding Documents to inquire and secure Supplemental/Bid Bulletins that may be issued by the BAC. However, Bidders who have submitted bids before the issuance of the Supplemental/Bid Bulletin must be informed and allowed to modify or withdraw their bids in accordance with **ITB** Clause 23.

## C. Preparation of Bids

### 11. Language of Bid

The Bid, as well as all correspondence and documents relating to the bid exchanged by the Consultant and the Procuring Entity, shall be written in English. If the eligibility requirements or statements, the bids, and all other documents submitted to the BAC are in foreign language other than English, it must be accompanied by a translation of the documents in English. The documents shall be translated by the relevant foreign government agency, the foreign government agency authorized to translate documents, or a registered translator in the foreign bidder's country; and shall be authenticated by the appropriate Philippine foreign service establishment/post or the equivalent office having jurisdiction over the foreign bidder's affairs in the Philippines. The English translation shall govern, for purposes of interpretation of the bid.

### 12. Documents Comprising the Bid: Eligibility and Technical Components

- 12.1. Unless otherwise indicated in the **BDS**, the first envelope shall contain the following eligibility and technical documents:
  - (a) Eligibility Documents –

Class "A" Documents:

- (i) Registration certificate from the Securities and Exchange Commission (SEC), Department of Trade and Industry (DTI) for sole proprietorship, or Cooperative Development Authority (CDA) for cooperatives, or any proof of such registration as stated in the **BDS**;
- (ii) Mayor's permit issued by the city or municipality where the principal place of business of the prospective bidder is located;
- (iii) Statement of all its ongoing government and private contracts, including contracts awarded but not yet started, if any, whether similar or not similar in nature and complexity to the contract to be bid; and

Statement identifying the bidder's single largest completed contract similar to the contract to be bid, except under conditions provided for in Sec. 23.5.1.3 of the IRR, within the relevant period as provided in the **BDS**.

The statement shall include, for each contract, the following:

- (iii.1) name of the contract;
- (iii.2) date of the contract;
- (iii.3) kinds of Goods;
- (iii.4) amount of contract and value of outstanding contracts;
- (iii.5) date of delivery; and
- (iii.6) end user's acceptance or official receipt(s) issued for the contract, if completed.
- (iv) Audited financial statements, stamped "received" by the Bureau of Internal Revenue (BIR) or its duly accredited and authorized institutions, for the preceding calendar year, which should not be earlier than two (2) years from bid submission;
- (v) NFCC computation in accordance with ITB Clause 5.5; and
- (vi) Tax clearance per Executive Order 398, Series of 2005, as finally reviewed and approved by the BIR.

Class "B" Document:

- (vii) If applicable, the JVA in case the joint venture is already in existence, or duly notarized statements from all the potential joint venture partners stating that they will enter into and abide by the provisions of the JVA in the instance that the bid is successful.



- (b) Technical Documents –
  - (i) Bid security in accordance with **ITB** Clause 18. If the Procuring Entity requires the bidders to submit the bid security in the form of:
    - (i.1) a bank draft/guarantee or an irrevocable letter of credit issued by a foreign bank, it shall be accompanied by a confirmation from a Universal or Commercial Bank; or
    - (i.2) a surety bond, it shall be accompanied by a certification by the Insurance Commission that the surety or insurance company is authorized to issue such instruments;
  - (ii) Conformity with technical specifications, as enumerated and specified in Sections VI and VII of the Bidding Documents; and
  - (iii) Sworn statement in accordance with Section 25.2(a)(iv) of the IRR of RA 9184 and using the form prescribed in Section VIII. Bidding Forms.

### 13. Documents Comprising the Bid: Financial Component

- 13.1. Unless otherwise stated in the **BDS**, the financial component of the bid shall contain the following:
  - (a) Financial Bid Form, which includes bid prices and the bill of quantities and the applicable Price Schedules, in accordance with **ITB** Clauses 15.1 and 15.4;
  - (b) If the Bidder claims preference as a Domestic Bidder or Domestic Entity, a certification from the DTI, SEC, or CDA issued in accordance with **ITB** Clause 27, unless otherwise provided in the **BDS**; and
  - (c) Any other document related to the financial component of the bid as stated in the **BDS**.
- 13.2. (a) Unless otherwise stated in the **BDS**, all bids that exceed the ABC shall not be accepted.
- (b) Unless otherwise indicated in the **BDS**, for foreign-funded procurement, a ceiling may be applied to bid prices provided the following conditions are met:
  - (i) Bidding Documents are obtainable free of charge on a freely accessible website. If payment of Bidding Documents is required by the procuring entity, payment could be made upon the submission of bids.

- (ii) The procuring entity has procedures in place to ensure that the ABC is based on recent estimates made by the responsible unit of the procuring entity and that the estimates reflect the quality, supervision and risk and inflationary factors, as well as prevailing market prices, associated with the types of works or goods to be procured.
- (iii) The procuring entity has trained cost estimators on estimating prices and analyzing bid variances.
- (iv) The procuring entity has established a system to monitor and report bid prices relative to ABC and engineer's/procuring entity's estimate.
- (v) The procuring entity has established a system to monitor and report bid prices relative to ABC and procuring entity's estimate. The procuring entity has established a monitoring and evaluation system for contract implementation to provide a feedback on actual total costs of goods and works.

#### **14. Alternative Bids**

Alternative Bids shall be rejected. For this purpose, alternative bid is an offer made by a Bidder in addition or as a substitute to its original bid which may be included as part of its original bid or submitted separately therewith for purposes of bidding. A bid with options is considered an alternative bid regardless of whether said bid proposal is contained in a single envelope or submitted in two (2) or more separate bid envelopes.

#### **15. Bid Prices**

- 15.1. The Bidder shall complete the appropriate Price Schedules included herein, stating the unit prices, total price per item, the total amount and the expected countries of origin of the Goods to be supplied under this Project.
- 15.2. The Bidder shall fill in rates and prices for all items of the Goods described in the Bill of Quantities. Bids not addressing or providing all of the required items in the Bidding Documents including, where applicable, Bill of Quantities, shall be considered non-responsive and, thus, automatically disqualified. In this regard, where a required item is provided, but no price is indicated, the same shall be considered as non-responsive, but specifying a "0" (zero) for the said item would mean that it is being offered for free to the Government.
- 15.3. The terms Ex Works (EXW), Cost, Insurance and Freight (CIF), Cost and Insurance Paid to (CIP), Delivered Duty Paid (DDP), and other trade terms used to describe the obligations of the parties, shall be governed by the rules prescribed in the current edition of the International Commercial Terms (INCOTERMS) published by the International Chamber of Commerce, Paris.
- 15.4. Prices indicated on the Price Schedule shall be entered separately in the following manner:

- (a) For Goods offered from within the Procuring Entity's country:
- (i) The price of the Goods quoted EXW (ex works, ex factory, ex warehouse, ex showroom, or off-the-shelf, as applicable), including all customs duties and sales and other taxes already paid or payable:
    - (i.1) on the components and raw material used in the manufacture or assembly of Goods quoted ex works or ex factory; or
    - (i.2) on the previously imported Goods of foreign origin quoted ex warehouse, ex showroom, or off-the-shelf and any Procuring Entity country sales and other taxes which will be payable on the Goods if the contract is awarded.
  - (ii) The price for inland transportation, insurance, and other local costs incidental to delivery of the Goods to their final destination.
  - (iii) The price of other (incidental) services, if any, listed in the **BDS**.
- (b) For Goods offered from abroad:
- (i) Unless otherwise stated in the **BDS**, the price of the Goods shall be quoted DDP with the place of destination in the Philippines as specified in the **BDS**. In quoting the price, the Bidder shall be free to use transportation through carriers registered in any eligible country. Similarly, the Bidder may obtain insurance services from any eligible source country.
  - (ii) The price of other (incidental) services, if any, listed in the **BDS**.

15.5. Prices quoted by the Bidder shall be fixed during the Bidder's performance of the contract and not subject to variation or price escalation on any account. A bid submitted with an adjustable price quotation shall be treated as non-responsive and shall be rejected, pursuant to ITB Clause 24.

All bid prices shall be considered as fixed prices, and therefore not subject to price escalation during contract implementation, except under extraordinary circumstances. Extraordinary circumstances refer to events that may be determined by the National Economic and Development Authority in accordance with the Civil Code of the Philippines, and upon the recommendation of the Procuring Entity. Nevertheless, in cases where the cost of the awarded contract is affected by any applicable new laws, ordinances, regulations, or other acts of the GOP, promulgated after the date of bid opening, a contract price adjustment shall be made or appropriate relief shall be applied on a no loss-no gain basis.

*gund*  
*at*

## 16. Bid Currencies

- 16.1. Prices shall be quoted in the following currencies:
- (a) For Goods that the Bidder will supply from within the Philippines, the prices shall be quoted in Philippine Pesos.
  - (b) For Goods that the Bidder will supply from outside the Philippines, the prices may be quoted in the currency(ies) stated in the **BDS**. However, for purposes of bid evaluation, bids denominated in foreign currencies shall be converted to Philippine currency based on the exchange rate as published in the BSP reference rate bulletin on the day of the bid opening.
- 16.2. If so allowed in accordance with ITB Clause 16.1, the Procuring Entity for purposes of bid evaluation and comparing the bid prices will convert the amounts in various currencies in which the bid price is expressed to Philippine Pesos at the foregoing exchange rates.
- 16.3. Unless otherwise specified in the BDS, payment of the contract price shall be made in Philippine Pesos.

## 17. Bid Validity

- 17.1. Bids shall remain valid for the period specified in the **BDS** which shall not exceed one hundred twenty (120) calendar days from the date of the opening of bids.
- 17.2. In exceptional circumstances, prior to the expiration of the Bid validity period, the Procuring Entity may request Bidders to extend the period of validity of their bids. The request and the responses shall be made in writing. The bid security described in ITB Clause 18 should also be extended corresponding to the extension of the bid validity period at the least. A Bidder may refuse the request without forfeiting its bid security, but his bid shall no longer be considered for further evaluation and award. A Bidder granting the request shall not be required or permitted to modify its bid.

## 18. Bid Security

- 18.1. The bid security in the amount stated in the **BDS** shall be equal to the percentage of the ABC in accordance with the following schedule:

Form of Bid Security	Amount of Bid Security (Equal to Percentage of the ABC)
(a) Cash or cashier's/manager's check issued by a Universal or Commercial Bank.	Two percent (2%)

(b) Bank draft/guarantee or irrevocable letter of credit issued by a Universal or Commercial Bank: Provided, however, that it shall be confirmed or authenticated by a Universal or Commercial Bank, if issued by a foreign bank.	
(c) Surety bond callable upon demand issued by a surety or insurance company duly certified by the Insurance Commission as authorized to issue such security.	Five percent (5%)
(d) Any combination of the items (a) to (c) above.	Proportionate to share of form with respect to total amount of security
(e) Bid Securing Declaration	No percentage required.

For biddings conducted by LGUs, the procuring entity may also require bidders to submit bid securities in the form of cashier's/manager's check, bank draft/guarantee, or irrevocable letter of credit from other banks certified by the BSP as authorized to issue such financial statement.

The Bid Securing Declaration mentioned above is an undertaking which states, among others, that the bidder shall enter into contract with the procuring entity and furnish the performance security required under ITB Clause 33.2, from receipt of the Notice of Award, and committing to pay the corresponding fine, and be suspended for a period of time from being qualified to participate in any government procurement activity in the event it violates any of the conditions stated therein as provided in the guidelines issued by the GPPB.

- 18.2. The bid security should be valid for the period specified in the **BDS**. Any bid not accompanied by an acceptable bid security shall be rejected by the Procuring Entity as non-responsive.
- 18.3. No bid securities shall be returned to bidders after the opening of bids and before contract signing, except to those that failed or declared as post-disqualified, upon submission of a written waiver of their right to file a motion for reconsideration and/or protest. Without prejudice on its forfeiture, bid securities shall be returned only after the bidder with the Lowest Calculated and Responsive Bid has signed the contract and furnished the performance security, but in no case later than the expiration of the bid security validity period indicated in ITB Clause 18.2.
- 18.4. Upon signing and execution of the contract pursuant to ITB Clause 32, and the posting of the performance security pursuant to ITB Clause 33, the successful Bidder's bid security will be discharged, but in no case later than the bid security validity period as indicated in the ITB Clause 18.2.
- 18.5. The bid security may be forfeited:

- (a) if a Bidder:
- (i) withdraws its bid during the period of bid validity specified in ITB Clause 17;
  - (ii) does not accept the correction of errors pursuant to ITB Clause 28.3(b);
  - (iii) fails to submit the requirements within the prescribed period or a finding against their veracity as stated in ITB Clause 29.2;
  - (iv) submission of eligibility requirements containing false information or falsified documents;
  - (v) submission of bids that contain false information or falsified documents, or the concealment of such information in the bids in order to influence the outcome of eligibility screening or any other stage of the public bidding;
  - (vi) allowing the use of one's name, or using the name of another for purposes of public bidding;
  - (vii) withdrawal of a bid, or refusal to accept an award, or enter into contract with the Government without justifiable cause, after the Bidder had been adjudged as having submitted the Lowest Calculated and Responsive Bid;
  - (viii) refusal or failure to post the required performance security within the prescribed time;
  - (ix) refusal to clarify or validate in writing its bid during post-qualification within a period of seven (7) calendar days from receipt of the request for clarification;
  - (x) any documented attempt by a bidder to unduly influence the outcome of the bidding in his favor;
  - (xi) failure of the potential joint venture partners to enter into the joint venture after the bid is declared successful; or
  - (xii) all other acts that tend to defeat the purpose of the competitive bidding, such as habitually withdrawing from bidding, submitting late Bids or patently insufficient bid, for at least three (3) times within a year, except for valid reasons.
- (b) if the successful Bidder:
- (i) fails to sign the contract in accordance with ITB Clause 32; or
  - (ii) fails to furnish performance security in accordance with ITB Clause 33.

## 19. Format and Signing of Bids

- 19.1. Bidders shall submit their bids through their duly authorized representative using the appropriate forms provided in Section VIII. Bidding Forms on or before the deadline specified in the ITB Clauses 21 in two (2) separate sealed bid envelopes, and which shall be submitted simultaneously. The first shall contain the technical component of the bid, including the eligibility requirements under ITB Clause 12.1, and the second shall contain the financial component of the bid.
- 19.2. Forms as mentioned in ITB Clause 19.1 must be completed without any alterations to their format, and no substitute form shall be accepted. All blank spaces shall be filled in with the information requested.
- 19.3. The Bidder shall prepare and submit an original of the first and second envelopes as described in ITB Clauses 12 and 13. In the event of any discrepancy between the original and the copies, the original shall prevail.
- 19.4. The bid, except for unamended printed literature, shall be signed, and each and every page thereof shall be initialed, by the duly authorized representative/s of the Bidder.
- 19.5. Any interlineations, erasures, or overwriting shall be valid only if they are signed or initialed by the duly authorized representative/s of the Bidder.

## 20. Sealing and Marking of Bids

- 20.1. Bidders shall enclose their original eligibility and technical documents described in ITB Clause 12 in one sealed envelope marked "ORIGINAL - TECHNICAL COMPONENT", and the original of their financial component in another sealed envelope marked "ORIGINAL - FINANCIAL COMPONENT", sealing them all in an outer envelope marked "ORIGINAL BID".
- 20.2. Each copy of the first and second envelopes shall be similarly sealed duly marking the inner envelopes as "COPY NO. \_\_\_ - TECHNICAL COMPONENT" and "COPY NO. \_\_\_ - FINANCIAL COMPONENT" and the outer envelope as "COPY NO. \_\_\_", respectively. These envelopes containing the original and the copies shall then be enclosed in one single envelope.
- 20.3. The original and the number of copies of the Bid as indicated in the **BDS** shall be typed or written in indelible ink and shall be signed by the bidder or its duly authorized representative/s.
- 20.4. All envelopes shall:
  - (a) contain the name of the contract to be bid in capital letters;
  - (b) bear the name and address of the Bidder in capital letters;

*good off 201*

- (c) be addressed to the Procuring Entity's BAC in accordance with ITB Clause 1.1;
  - (d) bear the specific identification of this bidding process indicated in the ITB Clause 1.2; and
  - (e) bear a warning "DO NOT OPEN BEFORE..." the date and time for the opening of bids, in accordance with ITB Clause 21.
- 20.5. If bids are not sealed and marked as required, the Procuring Entity will assume no responsibility for the misplacement or premature opening of the bid.

#### **D. Submission and Opening of Bids**

##### **21. Deadline for Submission of Bids**

Bids must be received by the Procuring Entity's BAC at the address and on or before the date and time indicated in the BDS.

##### **22. Late Bids**

Any bid submitted after the deadline for submission and receipt of bids prescribed by the Procuring Entity, pursuant to ITB Clause 21, shall be declared "Late" and shall not be accepted by the Procuring Entity.

##### **23. Modification and Withdrawal of Bids**

- 23.1. The Bidder may modify its bid after it has been submitted; provided that the modification is received by the Procuring Entity prior to the deadline prescribed for submission and receipt of bids. The Bidder shall not be allowed to retrieve its original bid, but shall be allowed to submit another bid equally sealed, properly identified, linked to its original bid marked as "TECHNICAL MODIFICATION" or "FINANCIAL MODIFICATION" and stamped "received" by the BAC. Bid modifications received after the applicable deadline shall not be considered and shall be returned to the Bidder unopened.
- 23.2. A Bidder may, through a Letter of Withdrawal, withdraw its bid after it has been submitted, for valid and justifiable reason; provided that the Letter of Withdrawal is received by the Procuring Entity prior to the deadline prescribed for submission and receipt of bids.
- 23.3. Bids requested to be withdrawn in accordance with ITB Clause 23.1 shall be returned unopened to the Bidders. A Bidder may also express its intention not to participate in the bidding through a letter which should reach and be stamped by the BAC before the deadline for submission and receipt of bids. A Bidder that withdraws its bid shall not be permitted to submit another bid, directly or indirectly, for the same contract.
- 23.4. No bid may be modified after the deadline for submission of bids. No bid may be withdrawn in the interval between the deadline for submission of bids and the expiration of the period of bid validity specified by the Bidder on the



Financial Bid Form. Withdrawal of a bid during this interval shall result in the forfeiture of the Bidder's bid security, pursuant to ITB Clause 18.5, and the imposition of administrative, civil and criminal sanctions as prescribed by RA 9184 and its IRR.

## 24. Opening and Preliminary Examination of Bids

- 24.1. The BAC shall open the first bid envelopes of Bidders in public as specified in the **BDS** to determine each Bidder's compliance with the documents prescribed in ITB Clause 12. For this purpose, the BAC shall check the submitted documents of each bidder against a checklist of required documents to ascertain if they are all present, using a non-discretionary "pass/fail" criterion. If a bidder submits the required document, it shall be rated "passed" for that particular requirement. In this regard, bids that fail to include any requirement or are incomplete or patently insufficient shall be considered as "failed". Otherwise, the BAC shall rate the said first bid envelope as "passed".
- 24.2. Unless otherwise specified in the BDS, immediately after determining compliance with the requirements in the first envelope, the BAC shall forthwith open the second bid envelope of each remaining eligible bidder whose first bid envelope was rated "passed". The second envelope of each complying bidder shall be opened within the same day. In case one or more of the requirements in the second envelope of a particular bid is missing, incomplete or patently insufficient, and/or if the submitted total bid price exceeds the ABC unless otherwise provided in ITB Clause 13.2, the BAC shall rate the bid concerned as "failed". Only bids that are determined to contain all the bid requirements for both components shall be rated "passed" and shall immediately be considered for evaluation and comparison.
- 24.3. Letters of withdrawal shall be read out and recorded during bid opening, and the envelope containing the corresponding withdrawn bid shall be returned to the Bidder unopened. If the withdrawing Bidder's representative is in attendance, the original bid and all copies thereof shall be returned to the representative during the bid opening. If the representative is not in attendance, the bid shall be returned unopened by registered mail. The Bidder may withdraw its bid prior to the deadline for the submission and receipt of bids, provided that the corresponding Letter of Withdrawal contains a valid authorization requesting for such withdrawal, subject to appropriate administrative sanctions.
- 24.4. If a Bidder has previously secured a certification from the Procuring Entity to the effect that it has previously submitted the above-enumerated Class "A" Documents, the said certification may be submitted in lieu of the requirements enumerated in ITB Clause 12.1(a), items (i) to (v).
- 24.5. In the case of an eligible foreign Bidder as described in ITB Clause 5, the Class "A" Documents described in ITB Clause 12.1(a) may be substituted with the appropriate equivalent documents, if any, issued by the country of the foreign Bidder concerned.

- 24.6. Each partner of a joint venture agreement shall likewise submit the requirements in ITB Clauses 12.1(a)(i) and 12.1(a)(ii). Submission of documents required under ITB Clauses 12.1(a)(iii) to 12.1(a)(v) by any of the joint venture partners constitutes compliance.
- 24.7. The Procuring Entity shall prepare the minutes of the proceedings of the bid opening that shall include, as a minimum: (a) names of Bidders, their bid price, bid security, findings of preliminary examination; and (b) attendance sheet. The BAC members shall sign the abstract of bids as read.

## **E. Evaluation and Comparison of Bids**

### **25. Process to be Confidential**

- 25.1. Members of the BAC, including its staff and personnel, as well as its Secretariat and TWG, are prohibited from making or accepting any kind of communication with any bidder regarding the evaluation of their bids until the issuance of the Notice of Award, unless otherwise allowed in the case of ITB Clause 26.
- 25.2. Any effort by a bidder to influence the Procuring Entity in the Procuring Entity's decision in respect of bid evaluation, bid comparison or contract award will result in the rejection of the Bidder's bid.

### **26. Clarification of Bids**

To assist in the evaluation, comparison, and post-qualification of the bids, the Procuring Entity may ask in writing any Bidder for a clarification of its bid. All responses to requests for clarification shall be in writing. Any clarification submitted by a Bidder in respect to its bid and that is not in response to a request by the Procuring Entity shall not be considered.

### **27. Domestic Preference**

- 27.1. Unless otherwise stated in the **BDS**, the Procuring Entity will grant a margin of preference for the purpose of comparison of bids in accordance with the following:
- (a) The preference shall be applied when (i) the lowest Foreign Bid is lower than the lowest bid offered by a Domestic Bidder, or (ii) the lowest bid offered by a non-Philippine national is lower than the lowest bid offered by a Domestic Entity.
  - (b) For evaluation purposes, the lowest Foreign Bid or the bid offered by a non-Philippine national shall be increased by fifteen percent (15%).
  - (c) In the event that (i) the lowest bid offered by a Domestic Entity does not exceed the lowest Foreign Bid as increased, or (ii) the lowest bid offered by a non-Philippine national as increased, then the Procuring Entity shall award the contract to the Domestic Bidder/Entity at the

amount of the lowest Foreign Bid or the bid offered by a non-Philippine national, as the case may be.

- (d) If the Domestic Entity/Bidder refuses to accept the award of contract at the amount of the Foreign Bid or bid offered by a non-Philippine national within two (2) calendar days from receipt of written advice from the BAC, the Procuring Entity shall award to the bidder offering the Foreign Bid or the non-Philippine national, as the case may be, subject to post-qualification and submission of all the documentary requirements under these Bidding Documents.

27.2. A Bidder may be granted preference as a Domestic Entity subject to the certification from the DTI (in case of sole proprietorships), SEC (in case of partnerships and corporations), or CDA (in case of cooperatives) that the (a) sole proprietor is a citizen of the Philippines or the partnership, corporation, cooperative, or association is duly organized under the laws of the Philippines with at least seventy five percent (75%) of its interest or outstanding capital stock belonging to citizens of the Philippines, (b) habitually established in business and habitually engaged in the manufacture or sale of the merchandise covered by his bid, and (c) the business has been in existence for at least five (5) consecutive years prior to the advertisement and/or posting of the Invitation to Bid for this Project.

27.3. A Bidder may be granted preference as a Domestic Bidder subject to the certification from the DTI that the Bidder is offering unmanufactured articles, materials or supplies of the growth or production of the Philippines, or manufactured articles, materials, or supplies manufactured or to be manufactured in the Philippines substantially from articles, materials, or supplies of the growth, production, or manufacture, as the case may be, of the Philippines.

## 28. Detailed Evaluation and Comparison of Bids

28.1. The Procuring Entity will undertake the detailed evaluation and comparison of bids which have passed the opening and preliminary examination of bids, pursuant to ITB Clause 24, in order to determine the Lowest Calculated Bid.

28.2. The Lowest Calculated Bid shall be determined in two steps:

- (a) The detailed evaluation of the financial component of the bids, to establish the correct calculated prices of the bids; and
- (b) The ranking of the total bid prices as so calculated from the lowest to the highest. The bid with the lowest price shall be identified as the Lowest Calculated Bid.

28.3. The Procuring Entity's BAC shall immediately conduct a detailed evaluation of all bids rated "passed," using non-discretionary pass/fail criteria. Unless otherwise specified in the **BDS**, the BAC shall consider the following in the evaluation of bids:

- (a) Completeness of the bid. Unless the ITB specifically allows partial bids, bids not addressing or providing all of the required items in the Schedule of Requirements including, where applicable, bill of quantities, shall be considered non-responsive and, thus, automatically disqualified. In this regard, where a required item is provided, but no price is indicated, the same shall be considered as non-responsive, but specifying a "0" (zero) for the said item would mean that it is being offered for free to the Procuring Entity; and
  - (b) Arithmetical corrections. Consider computational errors and omissions to enable proper comparison of all eligible bids. It may also consider bid modifications, if allowed in the **BDS**. Any adjustment shall be calculated in monetary terms to determine the calculated prices.
- 28.4. Based on the detailed evaluation of bids, those that comply with the above-mentioned requirements shall be ranked in the ascending order of their total calculated bid prices, as evaluated and corrected for computational errors, discounts and other modifications, to identify the Lowest Calculated Bid. Total calculated bid prices, as evaluated and corrected for computational errors, discounts and other modifications, which exceed the ABC shall not be considered, unless otherwise indicated in the **BDS**.
- 28.5. The Procuring Entity's evaluation of bids shall only be based on the bid price quoted in the Financial Bid Form.
- 28.6. Bids shall be evaluated on an equal footing to ensure fair competition. For this purpose, all bidders shall be required to include in their bids the cost of all taxes, such as, but not limited to, value added tax (VAT), income tax, local taxes, and other fiscal levies and duties which shall be itemized in the bid form and reflected in the detailed estimates. Such bids, including said taxes, shall be the basis for bid evaluation and comparison.

## 29. **Post-Qualification**

- 29.1. The Procuring Entity shall determine to its satisfaction whether the Bidder that is evaluated as having submitted the Lowest Calculated Bid (LCB) complies with and is responsive to all the requirements and conditions specified in ITB Clauses 5, 12, and 13.
- 29.2. Within a non-extendible period of three (3) calendar days from receipt by the bidder of the notice from the BAC that it submitted the LCB, the Bidder shall submit the following documentary requirements:
- (a) Latest income and business tax returns in the form specified in the **BDS**;
  - (b) Certificate of PhilGEPS Registration or PhilGEPS Registration Number if the procuring entity is a Philippine foreign office or post, provided that participating bidders should register with the PhilGEPS prior to bid opening; and

- (c) Other appropriate licenses and permits required by law and stated in the BDS.

Failure of the Bidder declared as Lowest Calculated Bid to duly submit the requirements under this Clause or a finding against the veracity of such shall be ground for forfeiture of the bid security and disqualification of the Bidder for award.

- 29.3. The determination shall be based upon an examination of the documentary evidence of the Bidder's qualifications submitted pursuant to ITB Clauses 12 and 13, as well as other information as the Procuring Entity deems necessary and appropriate, using a non-discretionary "pass/fail" criterion.
- 29.4. If the BAC determines that the Bidder with the Lowest Calculated Bid passes all the criteria for post-qualification, it shall declare the said bid as the Lowest Calculated Responsive Bid, and recommend to the Head of the Procuring Entity the award of contract to the said Bidder at its submitted price or its calculated bid price, whichever is lower.
- 29.5. A negative determination shall result in rejection of the Bidder's Bid, in which event the Procuring Entity shall proceed to the next Lowest Calculated Bid to make a similar determination of that Bidder's capabilities to perform satisfactorily. If the second Bidder, however, fails the post qualification, the procedure for post qualification shall be repeated for the Bidder with the next Lowest Calculated Bid, and so on until the Lowest Calculated Responsive Bid is determined for contract award.
- 29.6. Within a period not exceeding seven (7) calendar days from the date of receipt of the recommendation of the BAC, the Head of the Procuring Entity shall approve or disapprove the said recommendation. In the case of GOCCs and GFIs, the period provided herein shall be fifteen (15) calendar days.

### 30. Reservation Clause

- 30.1. Notwithstanding the eligibility or post-qualification of a Bidder, the Procuring Entity concerned reserves the right to review its qualifications at any stage of the procurement process if it has reasonable grounds to believe that a misrepresentation has been made by the said Bidder, or that there has been a change in the Bidder's capability to undertake the project from the time it submitted its eligibility requirements. Should such review uncover any misrepresentation made in the eligibility and bidding requirements, statements or documents, or any changes in the situation of the Bidder which will affect its capability to undertake the project so that it fails the preset eligibility or bid evaluation criteria, the Procuring Entity shall consider the said Bidder as ineligible and shall disqualify it from submitting a bid or from obtaining an award or contract.
- 30.2. Based on the following grounds, the Procuring Entity reserves the right to reject any and all bids, declare a failure of bidding at any time prior to the contract award, or not to award the contract, without thereby incurring any

liability, and make no assurance that a contract shall be entered into as a result of the bidding:

- (a) If there is *prima facie* evidence of collusion between appropriate public officers or employees of the Procuring Entity, or between the BAC and any of the Bidders, or if the collusion is between or among the bidders themselves, or between a Bidder and a third party, including any act which restricts, suppresses or nullifies or tends to restrict, suppress or nullify competition;
- (b) If the Procuring Entity's BAC is found to have failed in following the prescribed bidding procedures; or
- (c) For any justifiable and reasonable ground where the award of the contract will not redound to the benefit of the GOP as follows:
  - (i) If the physical and economic conditions have significantly changed so as to render the project no longer economically, financially or technically feasible as determined by the head of the procuring entity;
  - (ii) If the project is no longer necessary as determined by the head of the procuring entity; and
  - (iii) If the source of funds for the project has been withheld or reduced through no fault of the Procuring Entity.

30.3. In addition, the Procuring Entity may likewise declare a failure of bidding when:

- (a) No bids are received;
- (b) All prospective Bidders are declared ineligible;
- (c) All bids fail to comply with all the bid requirements or fail post-qualification; or
- (d) The Bidder with the Lowest Calculated Responsive Bid (LCRB) refuses, without justifiable cause to accept the award of contract, and no award is made.

## F. Award of Contract

### 31. Contract Award

- 31.1. Subject to ITB Clause 29, the Procuring Entity shall award the contract to the Bidder whose bid has been determined to be the LCRB.
- 31.2. Prior to the expiration of the period of bid validity, the Procuring Entity shall notify the successful Bidder in writing that its bid has been accepted, through a Notice of Award received personally or sent by registered mail or

electronically, receipt of which must be confirmed in writing within two (2) days by the Bidder with the LCRB and submitted personally or sent by registered mail or electronically to the Procuring Entity.

31.3. Notwithstanding the issuance of the Notice of Award, award of contract shall be subject to the following conditions:

- (a) Submission of the valid JVA, if applicable, within ten (10) calendar days from receipt by the Bidder of the notice from the BAC that the Bidder has the LCRB;
- (b) Posting of the performance security in accordance with ITB Clause 33;
- (c) Signing of the contract as provided in ITB Clause 32; and
- (d) Approval by higher authority, if required.

31.4. At the time of contract award, the Procuring Entity shall not increase or decrease the quantity of goods originally specified in Section VI. Schedule of Requirements.

## 32. Signing of the Contract

32.1. At the same time as the Procuring Entity notifies the successful Bidder that its bid has been accepted, the Procuring Entity shall send the Contract Form to the Bidder, which contract has been provided in the Bidding Documents, incorporating therein all agreements between the parties.

32.2. Within ten (10) calendar days from receipt of the Notice of Award, the successful Bidder shall post the required performance security and sign and date the contract and return it to the Procuring Entity.

32.3. The Procuring Entity shall enter into contract with the successful Bidder within the same ten (10) calendar day period provided that all the documentary requirements are complied with.

32.4. The following documents shall form part of the contract:

- (a) Contract Agreement;
- (b) Bidding Documents;
- (c) Winning bidder's bid, including the Technical and Financial Proposals, and all other documents/statements submitted;
- (d) Performance Security;
- (e) Credit line in accordance with ITB Clause 5.5, if applicable;
- (f) Notice of Award of Contract; and

- (g) Other contract documents that may be required by existing laws and/or specified in the **BDS**.

### 33. Performance Security

- 33.1. To guarantee the faithful performance by the winning Bidder of its obligations under the contract, it shall post a performance security within a maximum period of ten (10) calendar days from the receipt of the Notice of Award from the Procuring Entity and in no case later than the signing of the contract.
- 33.2. The procuring entity shall prescribe at least two (2) acceptable forms of performance security taken from two (2) categories below that bidders may opt to use, denominated in Philippine Pesos and posted in favor of the Procuring Entity in an amount equal to the percentage of the total contract price in accordance with the following schedule:

Form of Performance Security	Amount of Performance Security (Equal to Percentage of the Total Contract Price)
(a) Cash or cashier's/manager's check issued by a Universal or Commercial Bank.	Five percent (5%)
(b) Bank draft/guarantee or irrevocable letter of credit issued by a Universal or Commercial Bank: Provided, however, that it shall be confirmed or authenticated by a Universal or Commercial Bank, if issued by a foreign bank.	
(c) Surety bond callable upon demand issued by a surety or insurance company duly certified by the Insurance Commission as authorized to issue such security; and/or	Thirty percent (30%)
(d) Any combination of the foregoing.	Proportionate to share of form with respect to total amount of security

- 33.3. Failure of the successful Bidder to comply with the above-mentioned requirement shall constitute sufficient ground for the annulment of the award and forfeiture of the bid security, in which event the Procuring Entity shall initiate and complete the post qualification of the second Lowest Calculated Bid. The procedure shall be repeated until the LCRB is identified and selected for contract award. However if no Bidder passed post-qualification, the BAC shall declare the bidding a failure and conduct a re-bidding with re-advertisement.



**34. Notice to Proceed**

- 34.1. Within three (3) calendar days from the date of approval of the contract by the appropriate government approving authority, the Procuring Entity shall issue its Notice to Proceed to the Bidder.
- 34.2. The contract effectivity date shall be provided in the Notice to Proceed by the Procuring Entity, which date shall not be later than seven (7) calendar days from the issuance of the Notice to Proceed.

**35. Protest Mechanism**

Decision of the procuring entity at any stage of the procurement process may be questioned in accordance with Section 55 of the revised Implementing Rules and Regulations of Republic Act 9184.

*gal*  
*at*

## *Section III. Bid Data Sheet*

### **Bid Data Sheet**

ITB Clause	
1.1	The Procuring Entity is <b>Technical Education and Skills Development Authority (TESDA)</b> .
2	<p>The Funding Source is the Government of the Philippines (GOP) through TESDA Trust Fund Account in the amount of Six Million One Hundred Fifty-Four Thousand Nine Hundred Sixteen Pesos and 05/100 (Php6,154,916.05).</p> <p>The name of the Project is <b>Procurement of CMU Boxes, Tools and Equipment and Mock-ups for the Mobile Training Laboratories (MTLs) – Re-Bidding of Lots 1 to 8.</b></p>
3.1	No further instructions.
5.1	<p>Additional Eligibility of the Bidders:</p> <ol style="list-style-type: none"> <li>1. <b>The Bidder must have been in the business for at least five (5) years from the date of opening of bids;</b></li> <li>2. <b>If the bidder had a contract with TESDA, prior the bid opening for this project, said bidder must have satisfactorily performed its obligations without any adverse findings issued by competent authorities relative to the quality and cost of the goods supplied and delivered including period of delivery.</b></li> <li>3. <b>Pursuant to Section 23.5.1.3 of the Revised Implementing Rules and Regulations of Republic Act No. 9184, otherwise known as the Government Procurement Reform Act, which prescribes that the procuring entity may clarify in the Bidding Documents the definition or description of what it considers to be a similar project, a contract is similar to the contract to be bid if it involves goods of the same nature and complexity as those which are the subject of the public bidding concerned. In the case of this procurement, the goods subject of this public bidding pertain to CMU Boxes, Tools and Equipment and Mock-ups for the Mobile Training Laboratories (MTLs) of identified Technical Vocational Institutes (TVIs) as recipients of Mobile Training Laboratories (MTLs) Project. As such, the goods covered under the completed single contract of the bidder which must be equivalent to at least fifty percent (50%) of the ABC must have the same major categories of goods subject of this public bidding for the said contract to qualify as a contract similar to the contract to be bid.</b></li> </ol>

	<b>4. The bidder must submit its clearances from the National Labor Relations Commission (NLRC), Department of Labor and Employment (DOLE), Pag-ibig Fund, Social Security System (SSS) and Philippine Health Insurance Corporation (PhilHealth) during the bid opening as part of the eligibility requirements. Said clearances must be issued within three (3) months from the date of the bid opening.</b>
5.2	None of the circumstances mentioned in the ITB Clause exists in this Project. Foreign bidders, subject to ITB Clause 5.2(b), may participate in this Project.
5.4	The Bidder must have completed, within the period specified in the Invitation to Bid and ITB Clause 12.1(a)(iii), a single contract that is similar to this Project, equivalent to at least fifty percent (50%) of the ABC.
7	No further instructions.
8.1	Subcontracting is not allowed
8.2	Not applicable.
9.1	The Procuring Entity will hold a pre-bid conference for this Project on <b>21 October 2016, 2:00 p.m.</b> at the <b>CSA Conference Room, 2<sup>nd</sup> Floor, TESDA Administration Building, Taguig City.</b>
10.1	The Procuring Entity's address is:  <b>Technical Education and Skills Development Authority East Service Road South Luzon Expressway Taguig City, Metro Manila</b>  <b>Tel/Fax No. 893-8296</b>
12.1(a)	No further instructions.
12.1(a)(i)	No other acceptable proof of registration is recognized.
12.1(a)(iii)	The statement of all ongoing government and private contracts shall include all such contracts within the last five (5) years prior to the deadline for the submission and receipt of bids.
13.1	No additional requirements.
13.1(b)	No further instructions.
13.2	The ABC is <b>Php6,154,916.05</b> . Any bid with a financial component

Handwritten signature and initials in the bottom right corner of the page.

	exceeding this amount shall not be accepted.
15.4(a)(iii)	No incidental services are required.
15.4(b)	Not applicable
16.1(b)	The Bid prices for Goods supplied from outside of the Philippines shall be quoted in Philippine Pesos.
16.3	Not applicable.
17.1	Bids will be valid for one hundred twenty (120) calendar days.
18.1	The bid security shall be in the following amount: <ul style="list-style-type: none"> <li>1. <b>2% of ABC</b>, if bid security is in cash, cashier's/manager's check, bank draft/guarantee or irrevocable letter of credit (depending on the lot/s);</li> <li>2. <b>5% of ABC</b>, if bid security is in Surety Bond (depending on the lot/s);</li> <li>3. Bid Securing Declaration pursuant to GPPB Circular No. 01-2014 issued on 23 May 2014; or</li> <li>4. Any combination of the foregoing proportionate to the share of form with respect to total amount of security.</li> </ul>
18.2	The bid security shall be valid for one hundred twenty (120) calendar days.
20.3	Each Bidder shall submit one (1) original and three (3) copies of the first and second components of its bid.
21	The address for submission of bids is: <p style="text-align: center;"><b>TECHNICAL EDUCATION AND SKILLS DEVELOPMENT AUTHORITY ATTY. DIOSDADO O. PADILLA Deputy Director General TESD Operations Chairperson, BAC TESDA Complex, TESDA Administration Building East Service Road, SLEX Taguig City, Philippines</b></p> <p>The deadline for submission of bids is <b>08 November 2016 at 10:00 a.m.</b></p>
24.1	The place of bid opening is: <p style="text-align: center;"><b>CSA Conference Room, 2<sup>nd</sup> Floor, TESDA Administration Building Taguig City</b></p>

	The date and time of bid opening is <b>08 November 2016 at 10:15 a.m.</b>
24.2	No further instructions.
27.1	No further instructions.
28.3	<p>The bidding shall be done by lot. There are eight (8) lots. Only bids for all the items in each lot/qualification shall be accepted by the Procuring Entity. Bidders may bid for multiple lot/s qualifications where they think they are capable of supplying.</p> <p>Evaluation and award of contract will be undertaken depending on whatever is most advantageous to the government in terms of technical specifications and costs.</p>
28.3(b)	Bid modification is not allowed.
28.4	No further instructions.
29.2(a)	<p>Only tax returns filed and taxes paid through the BIR Electronic Filing and Payments System (EFPS) shall be accepted.</p> <p>NOTE: The latest income and business tax returns are those within the last six (6) months preceding the date of the submission of bid.</p>
29.2(b)	<i>List licenses and permits relevant to the Project and the corresponding law requiring it.</i>
32.4(g)	<i>List additional contract documents relevant to the Project that may be required by existing laws and/or the Procuring Entity.</i>

# *Section IV. General Conditions of Contract*

## TABLE OF CONTENTS

1. DEFINITIONS.....	37
2. CORRUPT, FRAUDULENT, COLLUSIVE, AND COERCIVE PRACTICES .....	38
3. INSPECTION AND AUDIT BY THE FUNDING SOURCE.....	39
4. GOVERNING LAW AND LANGUAGE .....	39
5. NOTICES .....	39
6. SCOPE OF CONTRACT .....	40
7. SUBCONTRACTING .....	40
8. PROCURING ENTITY'S RESPONSIBILITIES .....	40
9. PRICES .....	40
10. PAYMENT.....	41
11. ADVANCE PAYMENT AND TERMS OF PAYMENT.....	41
12. TAXES AND DUTIES .....	42
13. PERFORMANCE SECURITY .....	42
14. USE OF CONTRACT DOCUMENTS AND INFORMATION .....	43
15. STANDARDS .....	43
16. INSPECTION AND TESTS .....	43
17. WARRANTY .....	44
18. DELAYS IN THE SUPPLIER'S PERFORMANCE.....	44
19. LIQUIDATED DAMAGES.....	45
20. SETTLEMENT OF DISPUTES.....	45
21. LIABILITY OF THE SUPPLIER .....	46
22. FORCE MAJEURE .....	46
23. TERMINATION FOR DEFAULT .....	46
24. TERMINATION FOR INSOLVENCY.....	47
25. TERMINATION FOR CONVENIENCE.....	47

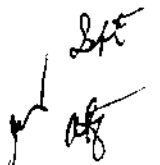

26. TERMINATION FOR UNLAWFUL ACTS ..... 48  
27. PROCEDURES FOR TERMINATION OF CONTRACTS ..... 48  
28. ASSIGNMENT OF RIGHTS ..... 49  
29. CONTRACT AMENDMENT..... 49  
30. APPLICATION ..... 50

*James [unclear]*  
*atg*

## 1. Definitions

1.1. In this Contract, the following terms shall be interpreted as indicated:

- (a) "The Contract" means the agreement entered into between the Procuring Entity and the Supplier, as recorded in the Contract Form signed by the parties, including all attachments and appendices thereto and all documents incorporated by reference therein.
- (b) "The Contract Price" means the price payable to the Supplier under the Contract for the full and proper performance of its contractual obligations.
- (c) "The Goods" means all of the supplies, equipment, machinery, spare parts, other materials and/or general support services which the Supplier is required to provide to the Procuring Entity under the Contract.
- (d) "The Services" means those services ancillary to the supply of the Goods, such as transportation and insurance, and any other incidental services, such as installation, commissioning, provision of technical assistance, training, and other such obligations of the Supplier covered under the Contract.
- (e) "GCC" means the General Conditions of Contract contained in this Section.
- (f) "SCC" means the Special Conditions of Contract.
- (g) "The Procuring Entity" means the organization purchasing the Goods, as named in the SCC.
- (h) "The Procuring Entity's country" is the Philippines.
- (i) "The Supplier" means the individual contractor, manufacturer distributor, or firm supplying/manufacturing the Goods and Services under this Contract and named in the SCC.
- (j) The "Funding Source" means the organization named in the SCC.
- (k) "The Project Site," where applicable, means the place or places named in the SCC.
- (l) "Day" means calendar day.
- (m) The "Effective Date" of the contract will be the date of receipt by the Supplier of the Notice to Proceed or the date provided in the Notice to Proceed. Performance of all obligations shall be reckoned from the Effective Date of the Contract.



- (n) "Verified Report" refers to the report submitted by the Implementing Unit to the Head of the Procuring Entity setting forth its findings as to the existence of grounds or causes for termination and explicitly stating its recommendation for the issuance of a Notice to Terminate.

## 2. Corrupt, Fraudulent, Collusive, and Coercive Practices

2.1. Unless otherwise provided in the SCC, the Procuring Entity as well as the bidders, contractors, or suppliers shall observe the highest standard of ethics during the procurement and execution of this Contract. In pursuance of this policy, the Procuring Entity:

- (a) defines, for the purposes of this provision, the terms set forth below as follows:

- (i) "corrupt practice" means behavior on the part of officials in the public or private sectors by which they improperly and unlawfully enrich themselves, others, or induce others to do so, by misusing the position in which they are placed, and it includes the offering, giving, receiving, or soliciting of anything of value to influence the action of any such official in the procurement process or in contract execution; entering, on behalf of the Government, into any contract or transaction manifestly and grossly disadvantageous to the same, whether or not the public officer profited or will profit thereby, and similar acts as provided in Republic Act 3019.

- (ii) "fraudulent practice" means a misrepresentation of facts in order to influence a procurement process or the execution of a contract to the detriment of the Procuring Entity, and includes collusive practices among Bidders (prior to or after bid submission) designed to establish bid prices at artificial, non-competitive levels and to deprive the Procuring Entity of the benefits of free and open competition.

- (iii) "collusive practices" means a scheme or arrangement between two or more Bidders, with or without the knowledge of the Procuring Entity, designed to establish bid prices at artificial, non-competitive levels.

- (iv) "coercive practices" means harming or threatening to harm, directly or indirectly, persons, or their property to influence their participation in a procurement process, or affect the execution of a contract;

- (v) "obstructive practice" is

- (aa) deliberately destroying, falsifying, altering or concealing of evidence material to an administrative proceedings or investigation or making false statements to investigators in order to materially impede an

administrative proceedings or investigation of the Procuring Entity or any foreign government/foreign or international financing institution into allegations of a corrupt, fraudulent, coercive or collusive practice; and/or threatening, harassing or intimidating any party to prevent it from disclosing its knowledge of matters relevant to the administrative proceedings or investigation or from pursuing such proceedings or investigation; or

(bb) acts intended to materially impede the exercise of the inspection and audit rights of the Procuring Entity or any foreign government/foreign or international financing institution herein.

(b) will reject a proposal for award if it determines that the Bidder recommended for award has engaged in any of the practices mentioned in this Clause for purposes of competing for the contract.

2.2. Further the Funding Source, Borrower or Procuring Entity, as appropriate, will seek to impose the maximum civil, administrative and/or criminal penalties available under the applicable law on individuals and organizations deemed to be involved with any of the practices mentioned in GCC Clause 2.1(a).

### **3. Inspection and Audit by the Funding Source**

The Supplier shall permit the Funding Source to inspect the Supplier's accounts and records relating to the performance of the Supplier and to have them audited by auditors appointed by the Funding Source, if so required by the Funding Source.

### **4. Governing Law and Language**

4.1. This Contract shall be interpreted in accordance with the laws of the Republic of the Philippines.

4.2. This Contract has been executed in the English language, which shall be the binding and controlling language for all matters relating to the meaning or interpretation of this Contract. All correspondence and other documents pertaining to this Contract exchanged by the parties shall be written in English.

### **5. Notices**

5.1. Any notice, request, or consent required or permitted to be given or made pursuant to this Contract shall be in writing. Any such notice, request, or consent shall be deemed to have been given or made when received by the concerned party, either in person or through an authorized representative of the Party to whom the communication is addressed, or when sent by registered mail, telex, telegram, or facsimile to such Party at the address specified in the

SCC, which shall be effective when delivered and duly received or on the notice's effective date, whichever is later.

- 5.2. A Party may change its address for notice hereunder by giving the other Party notice of such change pursuant to the provisions listed in the SCC for GCC Clause 5.1.

## 6. Scope of Contract

- 6.1. The GOODS and Related Services to be provided shall be as specified in Section VI. Schedule of Requirements.
- 6.2. This Contract shall include all such items, although not specifically mentioned, that can be reasonably inferred as being required for its completion as if such items were expressly mentioned herein. Any additional requirements for the completion of this Contract shall be provided in the SCC.

## 7. Subcontracting

- 7.1. Subcontracting of any portion of the Goods, if allowed in the **BDS**, does not relieve the Supplier of any liability or obligation under this Contract. The Supplier will be responsible for the acts, defaults, and negligence of any subcontractor, its agents, servants or workmen as fully as if these were the Supplier's own acts, defaults, or negligence, or those of its agents, servants or workmen.
- 7.2. Subcontractors disclosed and identified during the bidding may be changed during the implementation of this Contract, subject to compliance with the required qualifications and the approval of the Procuring Entity.

## 8. Procuring Entity's Responsibilities

- 8.1. Whenever the performance of the obligations in this Contract requires that the Supplier obtain permits, approvals, import, and other licenses from local public authorities, the Procuring Entity shall, if so needed by the Supplier, make its best effort to assist the Supplier in complying with such requirements in a timely and expeditious manner.
- 8.2. The Procuring Entity shall pay all costs involved in the performance of its responsibilities in accordance with GCC Clause 6.

## 9. Prices

- 9.1. For the given scope of work in this Contract as awarded, all bid prices are considered fixed prices, and therefore not subject to price escalation during contract implementation, except under extraordinary circumstances and upon prior approval of the GPPB in accordance with Section 61 of R.A. 9184 and its IRR or except as provided in this Clause.
- 9.2. Prices charged by the Supplier for Goods delivered and/or services performed under this Contract shall not vary from the prices quoted by the Supplier in its

bid, with the exception of any change in price resulting from a Change Order issued in accordance with GCC Clause 29.

## 10. Payment

- 10.1. Payments shall be made only upon a certification by the Head of the Procuring Entity to the effect that the Goods have been rendered or delivered in accordance with the terms of this Contract and have been duly inspected and accepted. Except with the prior approval of the President no payment shall be made for services not yet rendered or for supplies and materials not yet delivered under this Contract. Ten percent (10%) of the amount of each payment shall be retained by the Procuring Entity to cover the Supplier's warranty obligations under this Contract as described in GCC Clause 17.
- 10.2. The Supplier's request(s) for payment shall be made to the Procuring Entity in writing, accompanied by an invoice describing, as appropriate, the Goods delivered and/or Services performed, and by documents submitted pursuant to the SCC provision for GCC Clause 6.2, and upon fulfillment of other obligations stipulated in this Contract.
- 10.3. Pursuant to GCC Clause 10.2, payments shall be made promptly by the Procuring Entity, but in no case later than sixty (60) days after submission of an invoice or claim by the Supplier.
- 10.4. Unless otherwise provided in the SCC, the currency in which payment is made to the Supplier under this Contract shall be in Philippine Pesos.

## 11. Advance Payment and Terms of Payment

- 11.1. Advance payment shall be made only after prior approval of the President, and shall not exceed fifteen percent (15%) of the Contract amount, unless otherwise directed by the President or in cases allowed under Annex "D" of RA 9184.
- 11.2. For Goods supplied from abroad, the terms of payment shall be as follows:
  - (a) On Contract Signature: Fifteen Percent (15%) of the Contract Price shall be paid within sixty (60) days from signing of the Contract and upon submission of a claim and a bank guarantee for the equivalent amount valid until the Goods are delivered and in the form provided in Section VIII. Bidding Forms.
  - (b) On Delivery: Sixty-five percent (65%) of the Contract Price shall be paid to the Supplier within sixty (60) days after the date of receipt of the Goods and upon submission of the documents (i) through (vi) specified in the SCC provision on Delivery and Documents.
  - (c) On Acceptance: The remaining twenty percent (20%) of the Contract Price shall be paid to the Supplier within sixty (60) days after the date of submission of the acceptance and inspection certificate for the respective delivery issued by the Procuring Entity's authorized representative. In the event that no inspection or acceptance certificate

is issued by the Procuring Entity's authorized representative within forty five (45) days of the date shown on the delivery receipt the Supplier shall have the right to claim payment of the remaining twenty percent (20%) subject to the Procuring Entity's own verification of the reason(s) for the failure to issue documents (vii) and (viii) as described in the SCC provision on Delivery and Documents.

- 11.3. All progress payments shall first be charged against the advance payment until the latter has been fully exhausted.

## 12. Taxes and Duties

The Supplier, whether local or foreign, shall be entirely responsible for all the necessary taxes, stamp duties, license fees, and other such levies imposed for the completion of this Contract.

## 13. Performance Security

- 13.1. Within ten (10) calendar days from receipt of the Notice of Award from the Procuring Entity but in no case later than the signing of the contract by both parties, the successful Bidder shall furnish the performance security in any the forms prescribed in the ITB Clause 33.2.
- 13.2. The performance security posted in favor of the Procuring Entity shall be forfeited in the event it is established that the winning bidder is in default in any of its obligations under the contract.
- 13.3. The performance security shall remain valid until issuance by the Procuring Entity of the Certificate of Final Acceptance.
- 13.4. The performance security may be released by the Procuring Entity and returned to the Supplier after the issuance of the Certificate of Final Acceptance subject to the following conditions:
- (a) There are no pending claims against the Supplier or the surety company filed by the Procuring Entity;
  - (b) The Supplier has no pending claims for labor and materials filed against it; and
  - (c) Other terms specified in the SCC.
- 13.5. In case of a reduction of the contract value, the Procuring Entity shall allow a proportional reduction in the original performance security, provided that any such reduction is more than ten percent (10%) and that the aggregate of such reductions is not more than fifty percent (50%) of the original performance security.

Handwritten signature and initials in the bottom right corner of the page.

## 14. Use of Contract Documents and Information

- 14.1. The Supplier shall not, except for purposes of performing the obligations in this Contract, without the Procuring Entity's prior written consent, disclose this Contract, or any provision thereof, or any specification, plan, drawing, pattern, sample, or information furnished by or on behalf of the Procuring Entity. Any such disclosure shall be made in confidence and shall extend only as far as may be necessary for purposes of such performance.
- 14.2. Any document, other than this Contract itself, enumerated in GCC Clause 14.1 shall remain the property of the Procuring Entity and shall be returned (all copies) to the Procuring Entity on completion of the Supplier's performance under this Contract if so required by the Procuring Entity.

## 15. Standards

The Goods provided under this Contract shall conform to the standards mentioned in the Section VII. Technical Specifications; and, when no applicable standard is mentioned, to the authoritative standards appropriate to the Goods' country of origin. Such standards shall be the latest issued by the institution concerned.

## 16. Inspection and Tests

- 16.1. The Procuring Entity or its representative shall have the right to inspect and/or to test the Goods to confirm their conformity to the Contract specifications at no extra cost to the Procuring Entity. The SCC and Section VII. Technical Specifications shall specify what inspections and/or tests the Procuring Entity requires and where they are to be conducted. The Procuring Entity shall notify the Supplier in writing, in a timely manner, of the identity of any representatives retained for these purposes.
- 16.2. If applicable, the inspections and tests may be conducted on the premises of the Supplier or its subcontractor(s), at point of delivery, and/or at the goods' final destination. If conducted on the premises of the Supplier or its subcontractor(s), all reasonable facilities and assistance, including access to drawings and production data, shall be furnished to the inspectors at no charge to the Procuring Entity. The Supplier shall provide the Procuring Entity with results of such inspections and tests.
- 16.3. The Procuring Entity or its designated representative shall be entitled to attend the tests and/or inspections referred to in this Clause provided that the Procuring Entity shall bear all of its own costs and expenses incurred in connection with such attendance including, but not limited to, all traveling and board and lodging expenses.
- 16.4. The Procuring Entity may reject any Goods or any part thereof that fail to pass any test and/or inspection or do not conform to the specifications. The Supplier shall either rectify or replace such rejected Goods or parts thereof or make alterations necessary to meet the specifications at no cost to the

Procuring Entity, and shall repeat the test and/or inspection, at no cost to the Procuring Entity, upon giving a notice pursuant to GCC Clause 5.

- 16.5. The Supplier agrees that neither the execution of a test and/or inspection of the Goods or any part thereof, nor the attendance by the Procuring Entity or its representative, shall release the Supplier from any warranties or other obligations under this Contract.

## 17. Warranty

- 17.1. The Supplier warrants that the Goods supplied under the Contract are new, unused, of the most recent or current models, and that they incorporate all recent improvements in design and materials, except when the technical specifications required by the Procuring Entity provides otherwise.
- 17.2. The Supplier further warrants that all Goods supplied under this Contract shall have no defect, arising from design, materials, or workmanship or from any act or omission of the Supplier that may develop under normal use of the supplied Goods in the conditions prevailing in the country of final destination.
- 17.3. In order to assure that manufacturing defects shall be corrected by the Supplier, a warranty shall be required from the Supplier for a minimum period specified in the SCC. The obligation for the warranty shall be covered by, at the Supplier's option, either retention money in an amount equivalent to at least ten percent (10%) of the final payment, or a special bank guarantee equivalent to at least ten percent (10%) of the Contract Price or other such amount if so specified in the SCC. The said amounts shall only be released after the lapse of the warranty period specified in the SCC; provided, however, that the Supplies delivered are free from patent and latent defects and all the conditions imposed under this Contract have been fully met.
- 17.4. The Procuring Entity shall promptly notify the Supplier in writing of any claims arising under this warranty. Upon receipt of such notice, the Supplier shall, within the period specified in the SCC and with all reasonable speed, repair or replace the defective Goods or parts thereof, without cost to the Procuring Entity.
- 17.5. If the Supplier, having been notified, fails to remedy the defect(s) within the period specified in GCC Clause 17.4, the Procuring Entity may proceed to take such remedial action as may be necessary, at the Supplier's risk and expense and without prejudice to any other rights which the Procuring Entity may have against the Supplier under the Contract and under the applicable law.

## 18. Delays in the Supplier's Performance

- 18.1. Delivery of the Goods and/or performance of Services shall be made by the Supplier in accordance with the time schedule prescribed by the Procuring Entity in Section VI. Schedule of Requirements.

- 18.2. If at any time during the performance of this Contract, the Supplier or its Subcontractor(s) should encounter conditions impeding timely delivery of the Goods and/or performance of Services, the Supplier shall promptly notify the Procuring Entity in writing of the fact of the delay, its likely duration and its cause(s). As soon as practicable after receipt of the Supplier's notice, and upon causes provided for under GCC Clause 22, the Procuring Entity shall evaluate the situation and may extend the Supplier's time for performance, in which case the extension shall be ratified by the parties by amendment of Contract.
- 18.3. Except as provided under GCC Clause 22, a delay by the Supplier in the performance of its obligations shall render the Supplier liable to the imposition of liquidated damages pursuant to GCC Clause 19, unless an extension of time is agreed upon pursuant to GCC Clause 29 without the application of liquidated damages.

## **19. Liquidated Damages**

Subject to GCC Clauses 18 and 22, if the Supplier fails to satisfactorily deliver any or all of the Goods and/or to perform the Services within the period(s) specified in this Contract inclusive of duly granted time extensions if any, the Procuring Entity shall, without prejudice to its other remedies under this Contract and under the applicable law, deduct from the Contract Price, as liquidated damages, the applicable rate of one tenth (1/10) of one (1) percent of the cost of the unperformed portion for every day of delay until actual delivery or performance. The maximum deduction shall be ten percent (10%) of the amount of contract. Once the maximum is reached, the Procuring Entity shall rescind the Contract pursuant to GCC Clause 23, without prejudice to other courses of action and remedies open to it.

## **20. Settlement of Disputes**

- 20.1. If any dispute or difference of any kind whatsoever shall arise between the Procuring Entity and the Supplier in connection with or arising out of this Contract, the parties shall make every effort to resolve amicably such dispute or difference by mutual consultation.
- 20.2. If after thirty (30) days, the parties have failed to resolve their dispute or difference by such mutual consultation, then either the Procuring Entity or the Supplier may give notice to the other party of its intention to commence arbitration, as hereinafter provided, as to the matter in dispute, and no arbitration in respect of this matter may be commenced unless such notice is given.
- 20.3. Any dispute or difference in respect of which a notice of intention to commence arbitration has been given in accordance with this Clause shall be settled by arbitration. Arbitration may be commenced prior to or after delivery of the Goods under this Contract.
- 20.4. In the case of a dispute between the Procuring Entity and the Supplier, the dispute shall be resolved in accordance with Republic Act 9285 ("R.A. 9285"), otherwise known as the "Alternative Dispute Resolution Act of 2004."



20.5. Notwithstanding any reference to arbitration herein, the parties shall continue to perform their respective obligations under the Contract unless they otherwise agree; and the Procuring Entity shall pay the Supplier any monies due the Supplier.

## 21. Liability of the Supplier

21.1. The Supplier's liability under this Contract shall be as provided by the laws of the Republic of the Philippines, subject to additional provisions, if any, set forth in the SCC.

21.2. Except in cases of criminal negligence or willful misconduct, and in the case of infringement of patent rights, if applicable, the aggregate liability of the Supplier to the Procuring Entity shall not exceed the total Contract Price, provided that this limitation shall not apply to the cost of repairing or replacing defective equipment.

## 22. Force Majeure

22.1. The Supplier shall not be liable for forfeiture of its performance security, liquidated damages, or termination for default if and to the extent that the Supplier's delay in performance or other failure to perform its obligations under the Contract is the result of a *force majeure*.

22.2. For purposes of this Contract the terms "*force majeure*" and "fortuitous event" may be used interchangeably. In this regard, a fortuitous event or *force majeure* shall be interpreted to mean an event which the Contractor could not have foreseen, or which though foreseen, was inevitable. It shall not include ordinary unfavorable weather conditions; and any other cause the effects of which could have been avoided with the exercise of reasonable diligence by the Contractor. Such events may include, but not limited to, acts of the Procuring Entity in its sovereign capacity, wars or revolutions, fires, floods, epidemics, quarantine restrictions, and freight embargoes.

22.3. If a *force majeure* situation arises, the Supplier shall promptly notify the Procuring Entity in writing of such condition and the cause thereof. Unless otherwise directed by the Procuring Entity in writing, the Supplier shall continue to perform its obligations under the Contract as far as is reasonably practical, and shall seek all reasonable alternative means for performance not prevented by the *force majeure*.

## 23. Termination for Default

23.1. The Procuring Entity shall terminate this Contract for default when any of the following conditions attends its implementation:

- (a) Outside of *force majeure*, the Supplier fails to deliver or perform any or all of the Goods within the period(s) specified in the contract, or within any extension thereof granted by the Procuring Entity pursuant to a request made by the Supplier prior to the delay, and such failure amounts to at least ten percent (10%) of the contract price;

(b) As a result of *force majeure*, the Supplier is unable to deliver or perform any or all of the Goods, amounting to at least ten percent (10%) of the contract price, for a period of not less than sixty (60) calendar days after receipt of the notice from the Procuring Entity stating that the circumstance of force majeure is deemed to have ceased; or

(c) The Supplier fails to perform any other obligation under the Contract.

23.2. In the event the Procuring Entity terminates this Contract in whole or in part, for any of the reasons provided under GCC Clauses 23 to 26, the Procuring Entity may procure, upon such terms and in such manner as it deems appropriate, Goods or Services similar to those undelivered, and the Supplier shall be liable to the Procuring Entity for any excess costs for such similar Goods or Services. However, the Supplier shall continue performance of this Contract to the extent not terminated.

23.3. In case the delay in the delivery of the Goods and/or performance of the Services exceeds a time duration equivalent to ten percent (10%) of the specified contract time plus any time extension duly granted to the Supplier, the Procuring Entity may terminate this Contract, forfeit the Supplier's performance security and award the same to a qualified Supplier.

#### **24. Termination for Insolvency**

The Procuring Entity shall terminate this Contract if the Supplier is declared bankrupt or insolvent as determined with finality by a court of competent jurisdiction. In this event, termination will be without compensation to the Supplier, provided that such termination will not prejudice or affect any right of action or remedy which has accrued or will accrue thereafter to the Procuring Entity and/or the Supplier.

#### **25. Termination for Convenience**

25.1. The Procuring Entity may terminate this Contract, in whole or in part, at any time for its convenience. The Head of the Procuring Entity may terminate a contract for the convenience of the Government if he has determined the existence of conditions that make Project Implementation economically, financially or technically impractical and/or unnecessary, such as, but not limited to, fortuitous event(s) or changes in law and national government policies.

25.2. The Goods that have been delivered and/or performed or are ready for delivery or performance within thirty (30) calendar days after the Supplier's receipt of Notice to Terminate shall be accepted by the Procuring Entity at the contract terms and prices. For Goods not yet performed and/or ready for delivery, the Procuring Entity may elect:

(a) to have any portion delivered and/or performed and paid at the contract terms and prices; and/or

Handwritten signature and initials in the bottom right corner of the page.

- (b) to cancel the remainder and pay to the Supplier an agreed amount for partially completed and/or performed goods and for materials and parts previously procured by the Supplier.

25.3. If the Supplier suffers loss in its initial performance of the terminated contract, such as purchase of raw materials for goods specially manufactured for the Procuring Entity which cannot be sold in open market, it shall be allowed to recover partially from this Contract, on a *quantum meruit* basis. Before recovery may be made, the fact of loss must be established under oath by the Supplier to the satisfaction of the Procuring Entity before recovery may be made.

## 26. Termination for Unlawful Acts

26.1. The Procuring Entity may terminate this Contract in case it is determined *prima facie* that the Supplier has engaged, before or during the implementation of this Contract, in unlawful deeds and behaviors relative to contract acquisition and implementation. Unlawful acts include, but are not limited to, the following:

- (a) Corrupt, fraudulent, and coercive practices as defined in ITB Clause 3.1(a);
- (b) Drawing up or using forged documents;
- (c) Using adulterated materials, means or methods, or engaging in production contrary to rules of science or the trade; and
- (d) Any other act analogous to the foregoing.

## 27. Procedures for Termination of Contracts

27.1. The following provisions shall govern the procedures for termination of this Contract:

- (a) Upon receipt of a written report of acts or causes which may constitute ground(s) for termination as aforementioned, or upon its own initiative, the Implementing Unit shall, within a period of seven (7) calendar days, verify the existence of such ground(s) and cause the execution of a Verified Report, with all relevant evidence attached;
- (b) Upon recommendation by the Implementing Unit, the Head of the Procuring Entity shall terminate this Contract only by a written notice to the Supplier conveying the termination of this Contract. The notice shall state:
  - (i) that this Contract is being terminated for any of the ground(s) afore-mentioned, and a statement of the acts that constitute the ground(s) constituting the same;
  - (ii) the extent of termination, whether in whole or in part;

- (iii) an instruction to the Supplier to show cause as to why this Contract should not be terminated; and
  - (iv) special instructions of the Procuring Entity, if any.
- (c) The Notice to Terminate shall be accompanied by a copy of the Verified Report;
  - (d) Within a period of seven (7) calendar days from receipt of the Notice of Termination, the Supplier shall submit to the Head of the Procuring Entity a verified position paper stating why this Contract should not be terminated. If the Supplier fails to show cause after the lapse of the seven (7) day period, either by inaction or by default, the Head of the Procuring Entity shall issue an order terminating this Contract;
  - (e) The Procuring Entity may, at any time before receipt of the Supplier's verified position paper described in item (d) above withdraw the Notice to Terminate if it is determined that certain items or works subject of the notice had been completed, delivered, or performed before the Supplier's receipt of the notice;
  - (f) Within a non-extendible period of ten (10) calendar days from receipt of the verified position paper, the Head of the Procuring Entity shall decide whether or not to terminate this Contract. It shall serve a written notice to the Supplier of its decision and, unless otherwise provided, this Contract is deemed terminated from receipt of the Supplier of the notice of decision. The termination shall only be based on the ground(s) stated in the Notice to Terminate;
  - (g) The Head of the Procuring Entity may create a Contract Termination Review Committee (CTRC) to assist him in the discharge of this function. All decisions recommended by the CTRC shall be subject to the approval of the Head of the Procuring Entity; and
  - (h) The Supplier must serve a written notice to the Procuring Entity of its intention to terminate the contract at least thirty (30) calendar days before its intended termination. The Contract is deemed terminated if it is not resumed in thirty (30) calendar days after the receipt of such notice by the Procuring Entity.

## **28. Assignment of Rights**

The Supplier shall not assign his rights or obligations under this Contract, in whole or in part, except with the Procuring Entity's prior written consent.

## **29. Contract Amendment**

Subject to applicable laws, no variation in or modification of the terms of this Contract shall be made except by written amendment signed by the parties.



**30. Application**

These General Conditions shall apply to the extent that they are not superseded by provisions of other parts of this Contract.

*James B. [unclear]  
[unclear]*

## *Section V. Special Conditions of Contract*

### **Special Conditions of Contract**

GCC Clause	
1.1(g)	The Procuring Entity is <b>Technical Education and Skills Development Authority (TESDA)</b> .
1.1(i)	The Supplier is:
1.1(j)	The Funding Source is the <b>Government of the Philippines (GOP)</b> through the <b>TESDA trust fund account</b> in the amount of <b>Php6,154,916.05</b> .
1.1(k)	The Project Sites are <b>ten (10) provincial offices of TESDA, namely Apayao, Masbate, Eastern Samar, Northern Samar, Zamboanga del Norte, Camiguin, North Cotabato, Sarangani, Lanao del Sur and Maguindanao.</b>
5.1	<p>The Procuring Entity's address for Notices is:</p> <p><b>GUILING A. MAMONDIONG</b>                      Director General/Secretary  <b>Technical Education and Skills Development Authority</b>                      East Service Road                      South Luzon Expressway                      Taguig City, Metro Manila  <b>Philippines</b></p> <p><b>Tel/Fax No. 893-8296</b></p> <p>The Supplier's address for Notices is:</p> <p>_____</p> <p>_____</p> <p>_____</p>
6.2	<p><b>Delivery and Documents –</b></p> <p>For purposes of the Contract, "EXW," "FOB," "FCA," "CIF," "CIP," "DDP" and other trade terms used to describe the obligations of the parties shall have the meanings assigned to them by the current edition of INCOTERMS published by the International Chamber of Commerce, Paris. The Delivery terms of this Contract shall be as follows:</p> <p><i>For Goods Supplied from Abroad, state "The delivery terms applicable to the Contract are DDP delivered to various regional offices of TESDA. In accordance with INCOTERMS."</i></p>

*General MAMONDIONG*  
*AG*

*For Goods Supplied from Within the Philippines, state "The delivery terms applicable to this Contract are delivered to various regional offices of TESDA. Risk and title will pass from the Supplier to the Procuring Entity upon receipt and final acceptance of the Goods at their final destination."*

Delivery of the Goods shall be made by the Supplier in accordance with the terms specified in Section VI. Schedule of Requirements. The details of shipping and/or other documents to be furnished by the Supplier are as follows:

*For Goods supplied from within the Philippines:*

Upon delivery of the Goods to the Project Site, the Supplier shall notify the Procuring Entity and present the following documents to the Procuring Entity:

- (i) Original and four copies of the Supplier's invoice showing Goods' description, quantity, unit price, and total amount;
- (ii) Original and four copies delivery receipt/note, railway receipt, or truck receipt;
- (iii) Original Supplier's factory inspection report;
- (iv) Original and four copies of the Manufacturer's and/or Supplier's warranty certificate;
- (v) Original and four copies of the certificate of origin (for imported Goods);
- (vi) Delivery receipt detailing number and description of items received signed by the authorized receiving personnel;
- (vii) Certificate of Acceptance/Inspection Report signed by the Procuring Entity's representative at the Project Site; and
- (viii) Four copies of the Invoice Receipt for Property signed by the Procuring Entity's representative at the Project Site.

*For Goods supplied from abroad:*

Upon shipment, the Supplier shall notify the Procuring Entity and the insurance company by cable the full details of the shipment, including Contract Number, description of the Goods, quantity, vessel, bill of lading number and date, port of loading, date of shipment, port of discharge etc. Upon delivery to the Project Site, the Supplier shall notify the Procuring Entity and present the following documents as applicable with the documentary requirements of any letter of credit issued taking

*Handwritten signature/initials*

precedence:

- (i) Original and four copies of the Supplier's invoice showing Goods' description, quantity, unit price, and total amount;
- (ii) Original and four copies of the negotiable, clean shipped on board bill of lading marked "freight pre-paid" and five copies of the non-negotiable bill of lading ;
- (iii) Original Supplier's factory inspection report;
- (iv) Original and four copies of the Manufacturer's and/or Supplier's warranty certificate;
- (v) Original and four copies of the certificate of origin (for imported Goods);
- (vi) Delivery receipt detailing number and description of items received signed by the Procuring Entity's representative at the Project Site;
- (vii) Certificate of Acceptance/Inspection Report signed by the Procuring Entity's representative at the Project Site; and
- (viii) Four copies of the Invoice Receipt for Property signed by the Procuring Entity's representative at the Project Site.

For purposes of this Clause the Procuring Entity's Representative at the Project Site is the Regional Director.

**Incidental Services –**

The Supplier is required to provide all of the following services, including additional services, if any, specified in Section VI. Schedule of Requirements:

- (a) performance or supervision of on-site assembly and/or start-up of the supplied Goods;
- (b) furnishing of tools required for assembly and/or maintenance of the supplied Goods;
- (c) furnishing of a detailed operations and maintenance manual for each appropriate unit of the supplied Goods;
- (d) performance or supervision or maintenance and/or repair of the supplied Goods, for a period of time agreed by the parties, provided that this service shall not relieve the Supplier of any warranty obligations under this Contract; and
- (e) training of the Procuring Entity's personnel, at the Supplier's plant and/or on-site, in assembly, start-up, operation, maintenance, and/or repair of the supplied



**Goods.**

The Contract price for the Goods shall include the prices charged by the Supplier for incidental services and shall not exceed the prevailing rates charged to other parties by the Supplier for similar services.

**Spare Parts –**

The Supplier is required to provide all of the following materials, notifications, and information pertaining to spare parts manufactured or distributed by the Supplier:

- (a) such spare parts as the Procuring Entity may elect to purchase from the Supplier, provided that this election shall not relieve the Supplier of any warranty obligations under this Contract; and
- (b) in the event of termination of production of the spare parts:
  - i. advance notification to the Procuring Entity of the pending termination, in sufficient time to permit the Procuring Entity to procure needed requirements; and
  - ii. following such termination, furnishing at no cost to the Procuring Entity, the blueprints, drawings, and specifications of the spare parts, if requested.

The spare parts required are listed in Section VI. Schedule of Requirements and the cost thereof are included in the Contract Price

**Packaging –**

The Supplier shall provide such packaging of the Goods as is required to prevent their damage or deterioration during transit to their final destination, as indicated in this Contract. The packaging shall be sufficient to withstand, without limitation, rough handling during transit and exposure to extreme temperatures, salt and precipitation during transit, and open storage. Packaging case size and weights shall take into consideration, where appropriate, the remoteness of the GOODS' final destination and the absence of heavy handling facilities at all points in transit.

The packaging, marking, and documentation within and outside the packages shall comply strictly with such special requirements as shall be expressly provided for in the Contract, including additional requirements, if any, specified below, and

*Handwritten signature/initials*

in any subsequent instructions ordered by the Procuring Entity.

The outer packaging must be clearly marked on at least four (4) sides as follows:

Name of the Procuring Entity

Name of the Supplier

Contract Description

Final Destination

Gross weight

Any special lifting instructions

Any special handling instructions

Any relevant HAZCHEM classifications

A packaging list identifying the contents and quantities of the package is to be placed on an accessible point of the outer packaging if practical. If not practical the packaging list is to be placed inside the outer packaging but outside the secondary packaging.

**Insurance –**

The Goods supplied under this Contract shall be fully insured by the Supplier in a freely convertible currency against loss or damage incidental to manufacture or acquisition, transportation, storage, and delivery. The Goods remain at the risk and title of the Supplier until their final acceptance by the Procuring Entity.

**Transportation –**

Where the Supplier is required under Contract to deliver the Goods CIF, CIP or DDP, transport of the Goods to the port of destination or such other named place of destination in the Philippines, as shall be specified in this Contract, shall be arranged and paid for by the Supplier, and the cost thereof shall be included in the Contract Price.

Where the Supplier is required under this Contract to transport the Goods to a specified place of destination within the Philippines, defined as the Project Site, transport to such place of destination in the Philippines, including insurance and storage, as shall be specified in this Contract, shall be arranged by the Supplier, and related costs shall be included in the Contract Price.

Where the Supplier is required under Contract to deliver the Goods CIF, CIP or DDP, Goods are to be transported on

	<p>carriers of Philippine registry. In the event that no carrier of Philippine registry is available, Goods may be shipped by a carrier which is not of Philippine registry provided that the Supplier obtains and presents to the Procuring Entity certification to this effect from the nearest Philippine consulate to the port of dispatch. In the event that carriers of Philippine registry are available but their schedule delays the Supplier in its performance of this Contract the period from when the Goods were first ready for shipment and the actual date of shipment the period of delay will be considered <i>force majeure</i> in accordance with GCC Clause 22.</p> <p>The Procuring Entity accepts no liability for the damage of Goods during transit other than those prescribed by INCOTERMS for DDP Deliveries. In the case of Goods supplied from within the Philippines or supplied by domestic Suppliers risk and title will not be deemed to have passed to the Procuring Entity until their receipt and final acceptance at the final destination.</p> <p><b>Patent Rights –</b></p> <p>The Supplier shall indemnify the Procuring Entity against all third-party claims of infringement of patent, trademark, or industrial design rights arising from use of the Goods or any part thereof.</p>
9	For the given scope of work in this Contract as awarded, all bid prices are considered fixed prices, and therefore not subject to price escalation during contract implementation, except under extraordinary circumstances and upon prior approval of the GPPB in accordance with Section 61 of R.A. 9184 and its IRR-A.
10.4	Not applicable.
13.4(c)	No further instructions.
16.1	The inspections and tests that will be conducted are: <i>[insert the applicable inspections and tests, if none, state "None"]</i> .
17.3	<p><i>If the Goods pertain to Expendable Supplies:</i> Three (3) months after acceptance by the Procuring Entity of the delivered Goods or after the Goods are consumed, whichever is earlier.</p> <p><i>If the Goods pertain to Non-expendable Supplies:</i> One (1) year after acceptance by the Procuring Entity of the delivered Goods.</p>
17.4	The period for correction of defects in the warranty period is <i>[insert number of days]</i> .
19	The applicable rate is one tenth (1/10) of one (1) percent of the cost of the unperformed portion for every day of delay until

*Handwritten signature/initials*

	<p>actual delivery or performance.</p> <p>The maximum deduction shall be ten percent (10%) of the amount of contract. Once the maximum is reached, the Procuring Entity shall rescind the Contract pursuant to <b>GCC Clause 23</b>, without prejudice to other courses of action and remedies open to it</p>
20.4	<p>In the case of a dispute between the Procuring Entity and the Supplier, the dispute shall be resolved in accordance with Republic Act 9285 ("R.A. 9285"), otherwise known as the "Alternative Dispute Resolution Act of 2004."</p>
21.1	<p>No additional provision.</p>

*at  
per*

## ***Section VI. Schedule of Requirements***

### **A. List of Goods and Related Services**

The goods and related services refer to supply, delivery, installation, testing and training of end-user's representatives on the use of training tools and equipment. **Only bids for all the items in each lot shall be accepted. The bidding shall be done by lot. There are eight (8) lots. All bidders must bid for all items in a lot. However, evaluation and award of contract will be undertaken depending on whatever is most advantageous to the government in terms of technical specifications and costs.**

<b>Lot No.</b>	<b>QUALIFICATIONS</b>
1.	Common Box for Multimedia Equipment & Accessories and Mock-up
2.	Appliance Repair NC II with Toolbox
3.	Bread and Pastry NC II
4.	Cookery NC II with Plastic Box
5.	Electrical Installation and Maintenance NC II with Toolbox
6.	Food Processing NC II with Plastic Box
7.	Plumbing NC II
8.	Small Engine Repair (Motorcycle/Small Engine Servicing NC II) with Toolbox

### **B. Delivery and Completion Schedule**

The delivery period shall start from the date of the Notice to Proceed. No partial shipment shall be allowed. **Completion of the contract shall be made not later than ninety (90) calendar days from the date of the receipt by the winning bidder of the Notice to Proceed.**

## *Section VII. Technical Specifications*

<b>Item</b>	<b>Specification</b>	<b>Statement of Compliance</b>
	<b>See attached Technical specifications</b>	

*alt  
sent per*

**COMPARATIVE TECHNICAL SPECIFICATION**

TESDA'S SPECIFICATIONS			BIDDER'S SPECIFICATIONS	
No.	Item	Specifications	Item/Brand/Model	Specifications
Lot 1	Common Box for Multimedia Equipment & Accessories and Mock-up  MTL Box No. 1	Please refer to the attached drawing		

Name of Bidder: \_\_\_\_\_

Name and Signature of Authorized Representative: \_\_\_\_\_

Position/Designation: \_\_\_\_\_

Date: \_\_\_\_\_

*Handwritten notes:*  
 8/20  
 J...  
 2/18

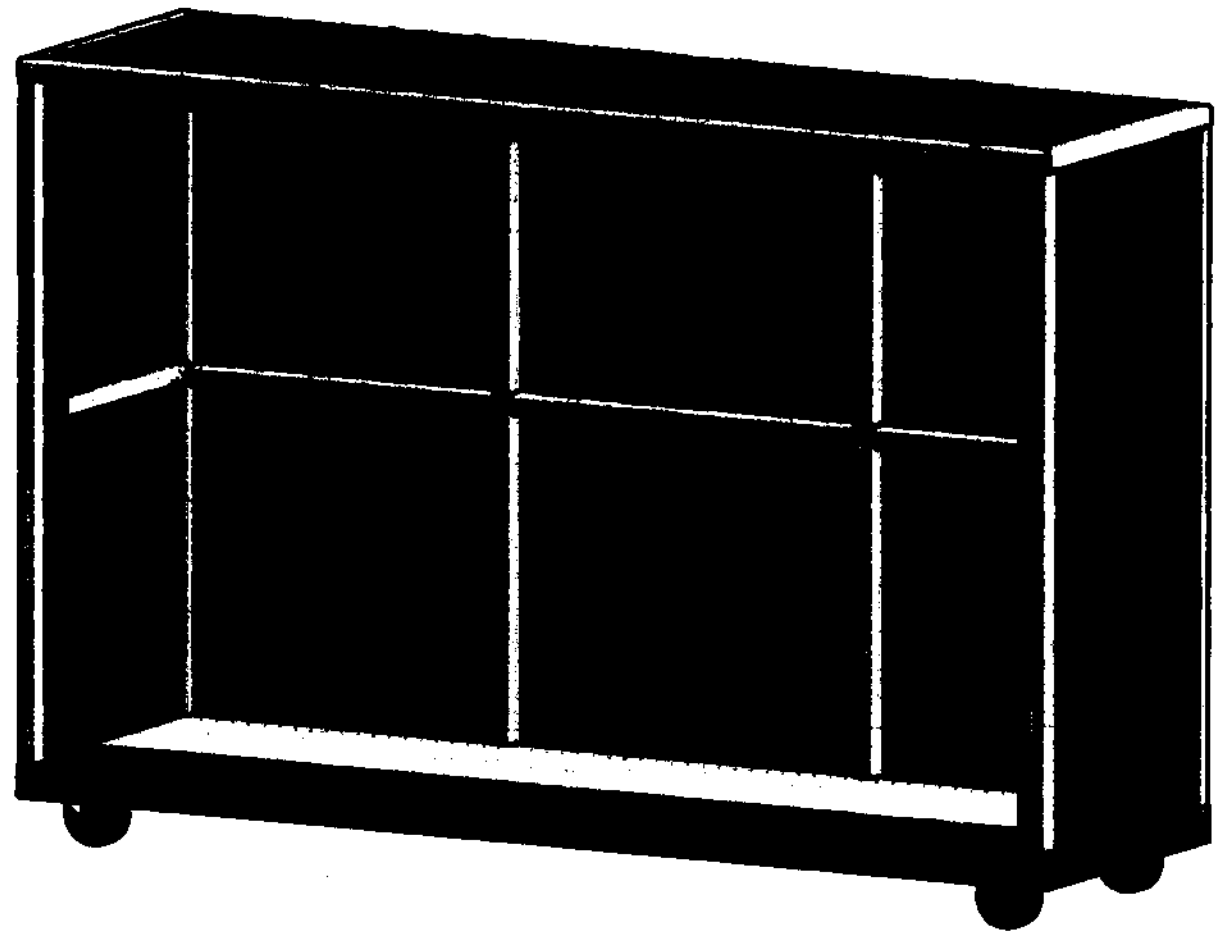

**MTL BOX NO. 1  
(COMMON BOX)**  
**QUANTITY:**  
(The door is not shown in the drawing)

*Handwritten initials and marks, possibly 'JPA' and '1/10'.*



**TECHNICAL  
EDUCATION AND  
SKILLS  
DEVELOPMENT  
AUTHORITY**

**PROJECT TITLE:**  
**MOBILE TRAINING  
LABORATORY**

**DRAWN BY:** JPA | **Scale:** 1:10 | **Sheet No.:** 1 /



MTL BOX 1 FRAME			
NO.	MATERIAL	LENGTH, mm	Qty.
1	2" x 2" x 3/16" angle bar	1,600.00	2
2	2" x 2" x 3/16" angle bar	500.00	2
3	1 1/4" x 1 1/4" x 2 mm square tube	493.65	2
4	1 1/4" x 1 1/4" x 2 mm square tube	968.25	6
5	1 1/4" x 1 1/4" x 2 mm square tube	1,600.00	2
6	1 1/4" x 1 1/4" x 2 mm square tube	500.00	2
7	1 1/4" x 1 1/4" x 2 mm square tube	436.50	2
8	1 1/4" x 1 1/4" x 2 mm square tube	1,473.00	1
9	1" x 1" x 1.5 mm square tube	436.50	2
TOTAL			21

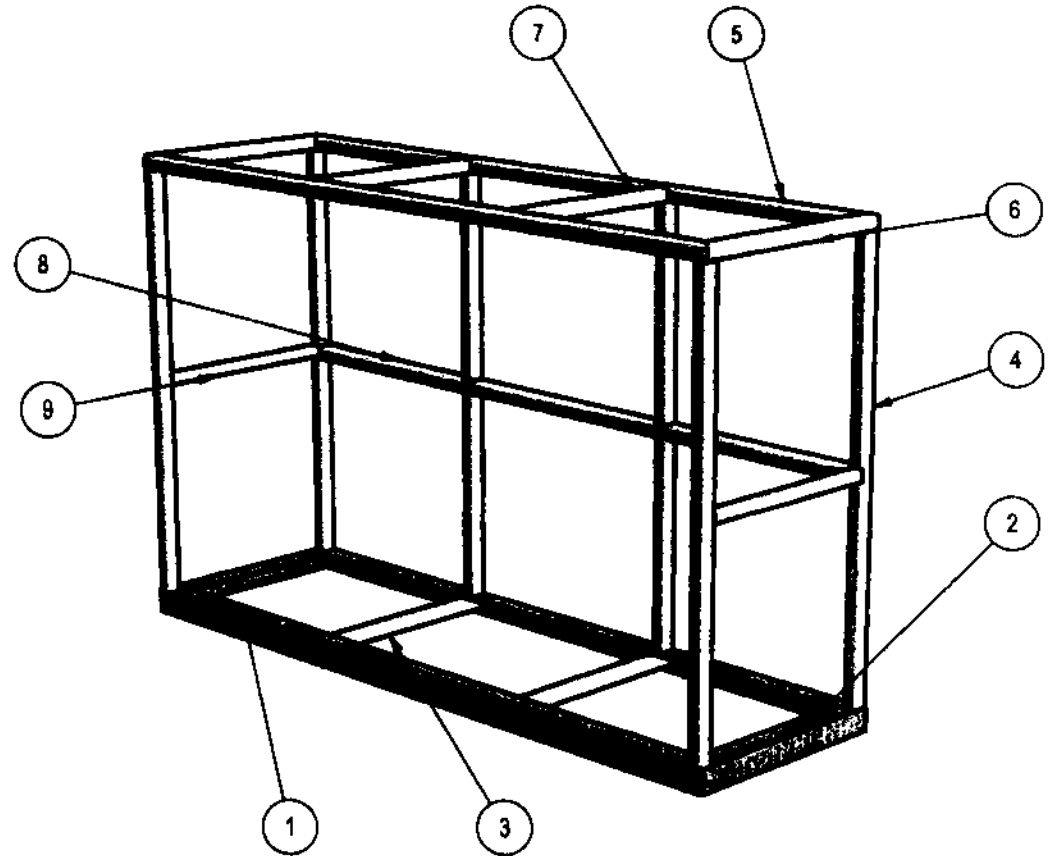

**MTL BOX NO. 1 FRAME  
(COMMON BOX)**  
(The door is not shown in the drawing)

	<b>TECHNICAL EDUCATION AND SKILLS DEVELOPMENT AUTHORITY</b>	PROJECT TITLE: <b>MOBILE TRAINING LABORATORY</b>	
	DRAWN BY: JPA	Scale: 1:15	Sheet No.: 17

*Handwritten initials and a signature.*

**MTL BOX NO. 1**

- ⊕ All materials must be painted with anti-corrosive primer
- ⊕ □ tube and ∟ bar are coated with light gray epoxy finish paint

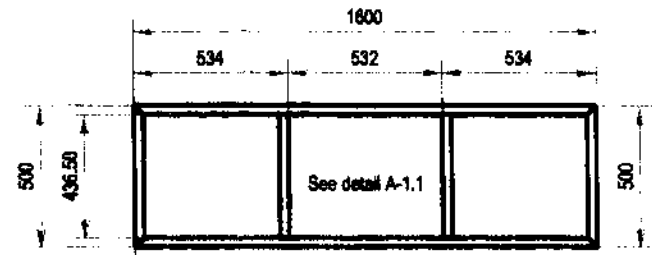

TOP VIEW

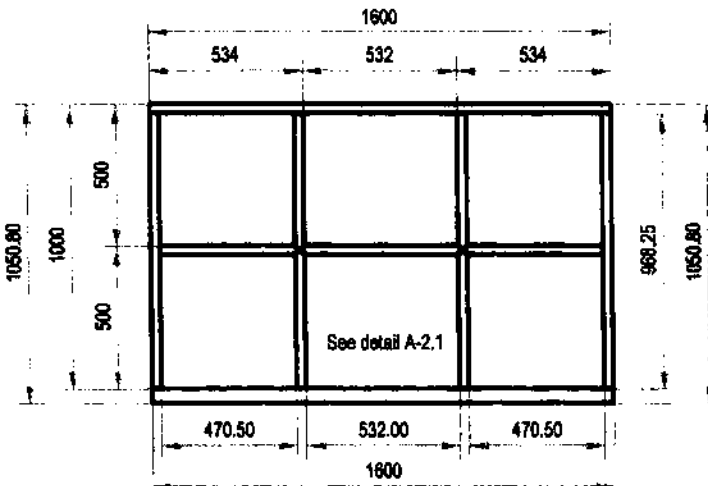

FRONT VIEW

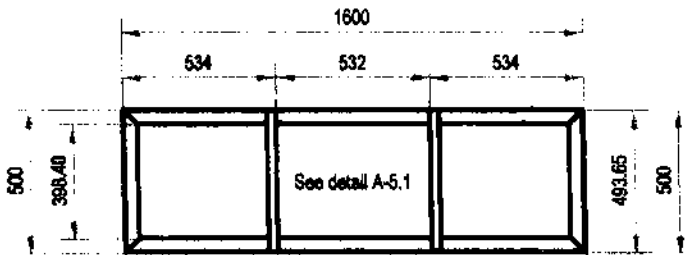

BOTTOM VIEW

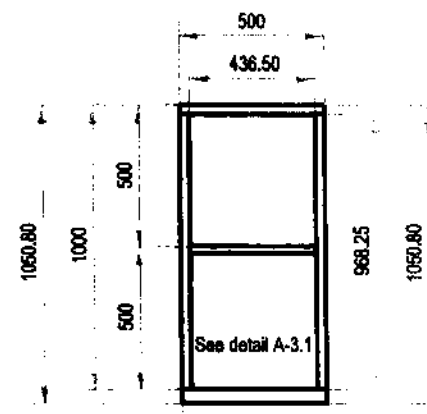

RIGHT SIDE VIEW

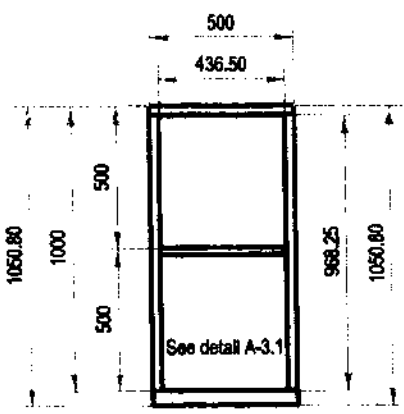

LEFT SIDE VIEW

PRODUCED BY AN AUTODESK EDUCATIONAL PRODUCT

PRODUCED BY AN AUTODESK EDUCATIONAL PRODUCT

**MTL BOX NO. 1 FRAME  
(COMMON BOX)**

(The door is not shown in the drawing)

	<b>TECHNICAL EDUCATION AND SKILLS DEVELOPMENT AUTHORITY</b>	<b>PROJECT TITLE: MOBILE TRAINING LABORATORY</b>

**DETAIL A-1.1:**

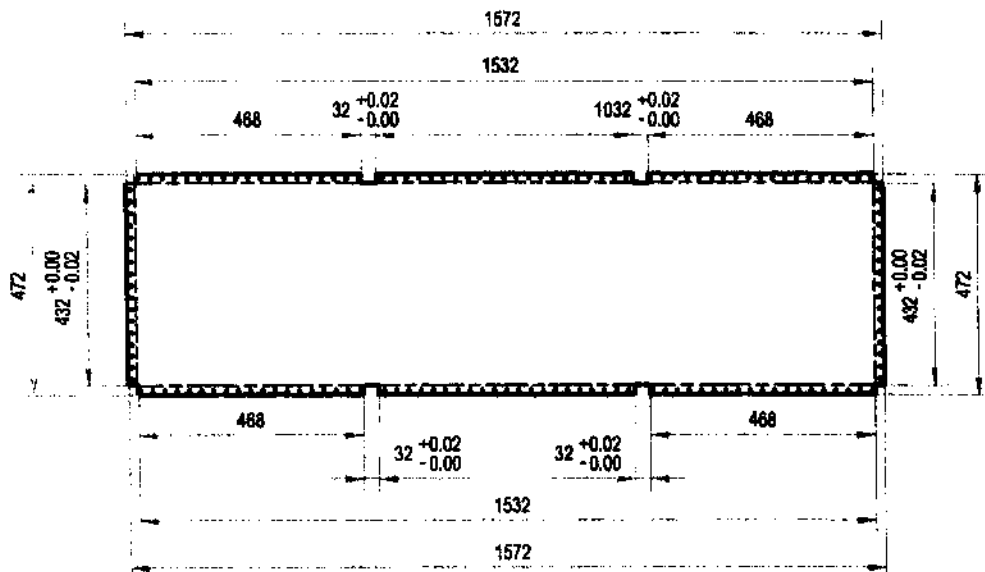

QUANTITY: 5

**DETAIL A-1.3:**

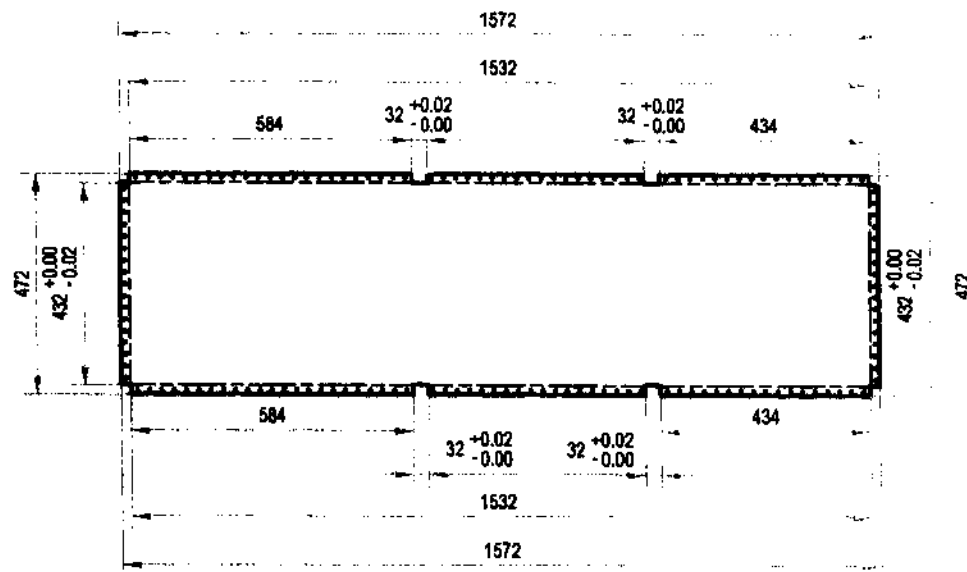

QUANTITY: 1

**DETAIL A-1.2:**

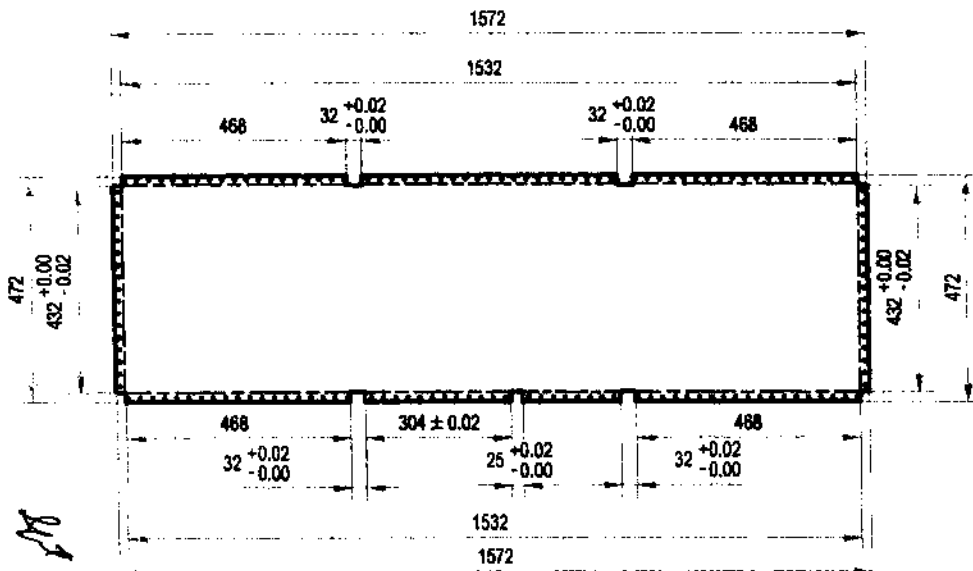

QUANTITY: 2

FLAT PATTERN: GALVANIZED SHEET GAUGE #18, PAINTED

**DETAIL A-1.4:**

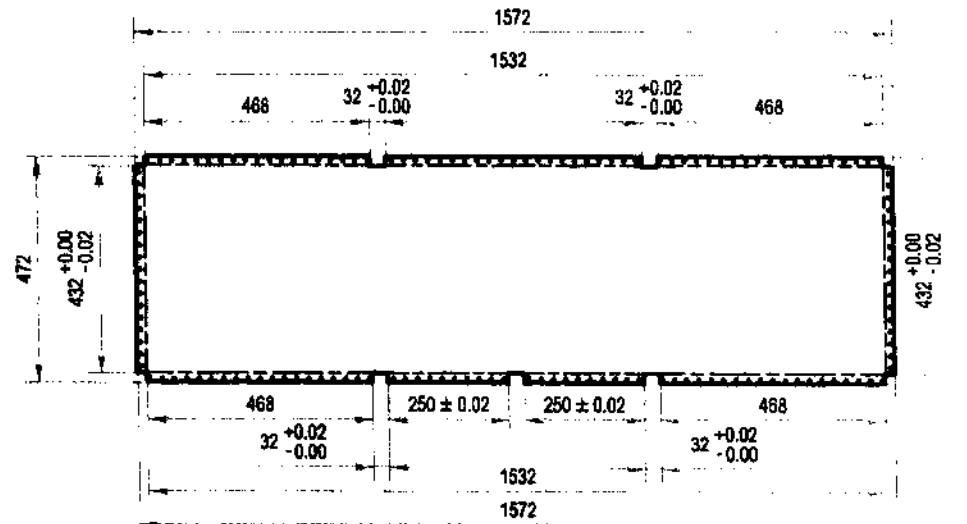

QUANTITY: 2

Use 3/16" blind rivet spaced @ 1" O.C.



TECHNICAL  
EDUCATION AND  
SKILLS  
DEVELOPMENT  
AUTHORITY

PROJECT TITLE:  
**MOBILE TRAINING  
LABORATORY**

DRAWN BY: JPA Scale: 1:15 Sheet No.

DETAIL A-2.1:

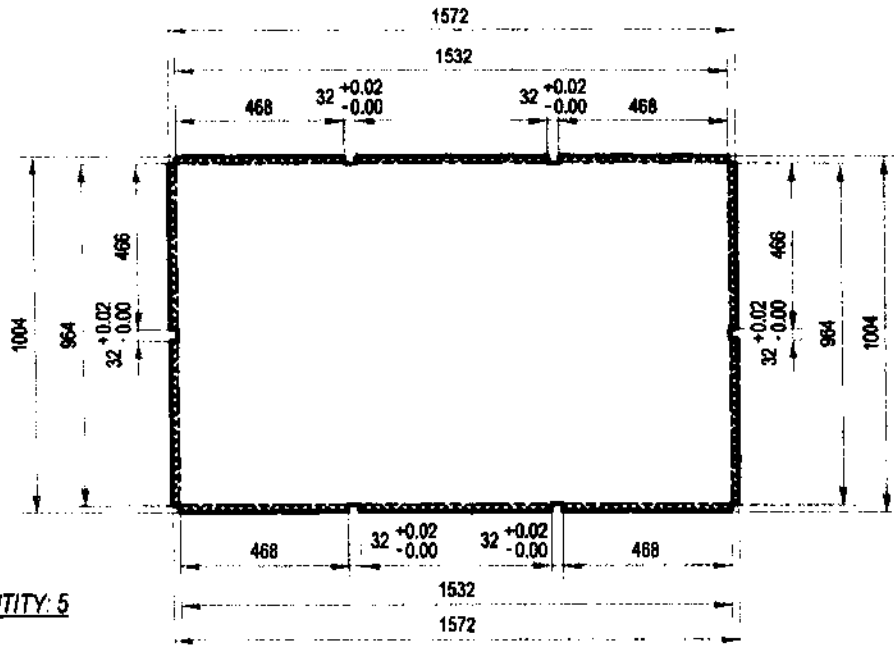

QUANTITY: 5

DETAIL A-2.3:

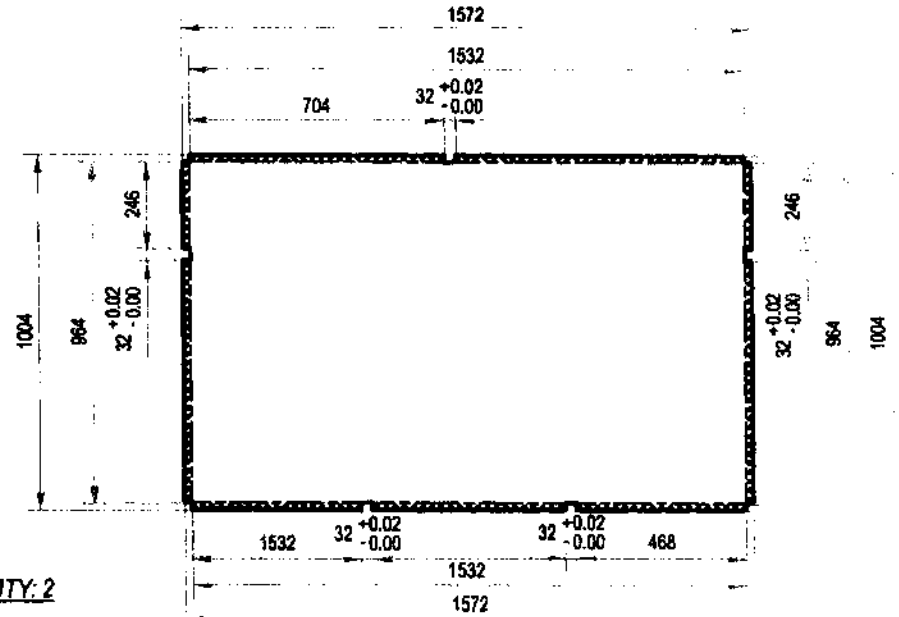

QUANTITY: 2

DETAIL A-2.2:

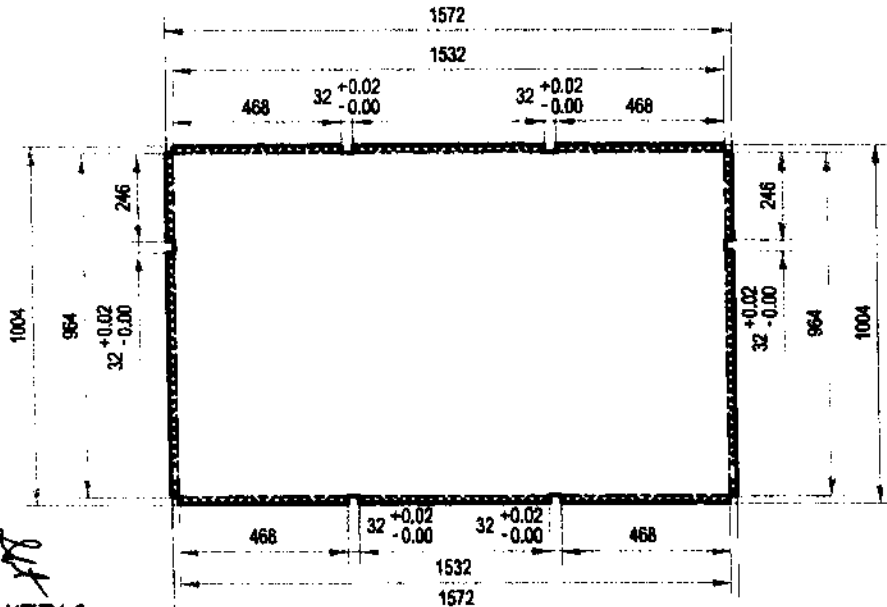

QUANTITY: 2

DETAIL A-2.4:

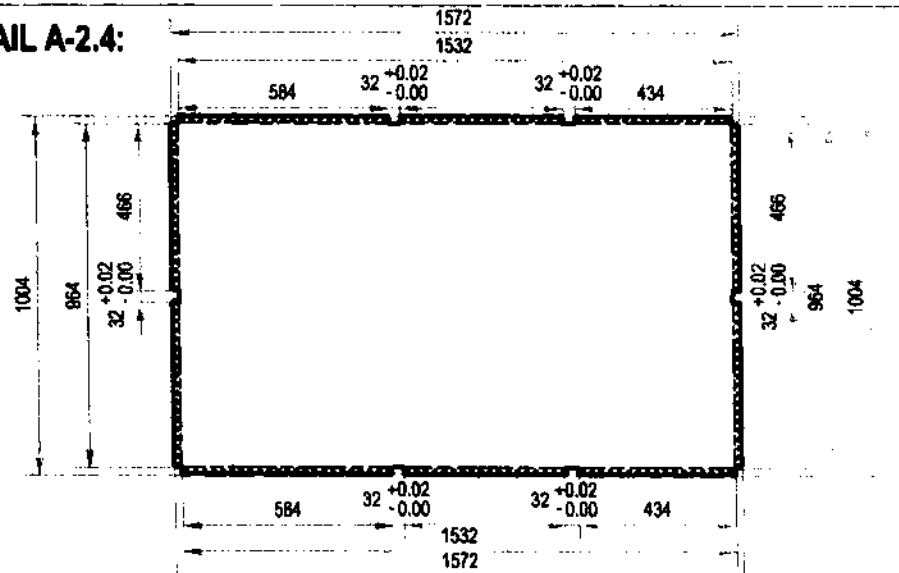

QUANTITY: 1

Use 3/8" blind rivet spaced @ 1" O.C.



TECHNICAL  
EDUCATION AND  
SKILLS  
DEVELOPMENT  
AUTHORITY

PROJECT TITLE:  
MOBILE TRAINING  
LABORATORY

DRAWN BY: JPA Scale: 1:10 Sheet No.:

FLAT PATTERN: GALVANIZED SHEET GAUGE #18, PAINTED

DETAIL A-3.1:

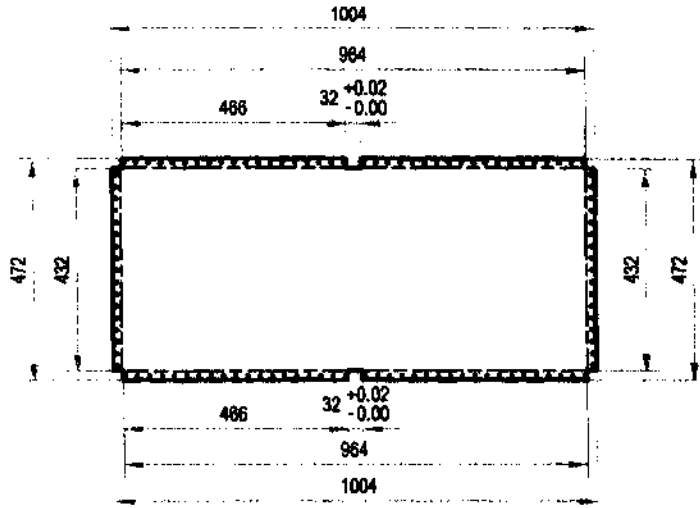

QUANTITY: 5

DETAIL A-3.3:

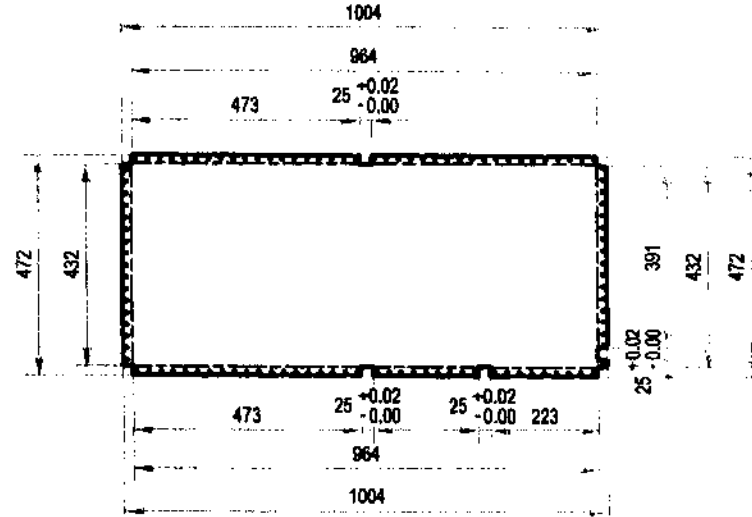

QUANTITY: 1

DETAIL A-3.2:

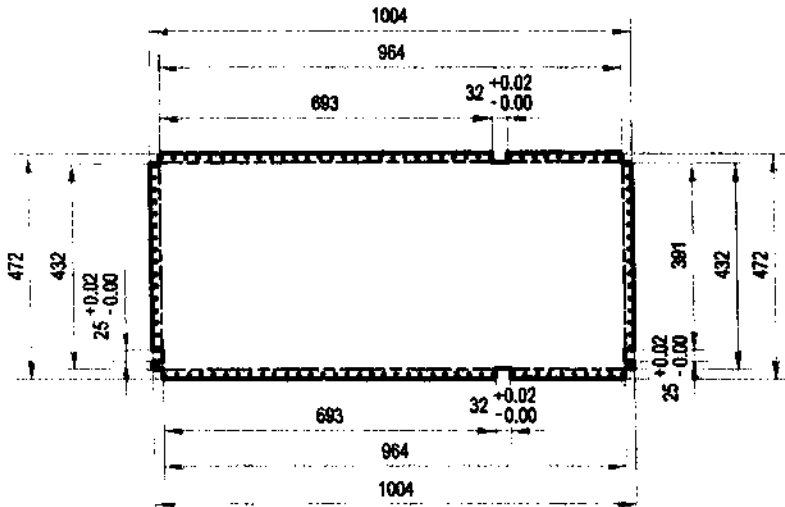

QUANTITY: 4

DETAIL A-3.4:

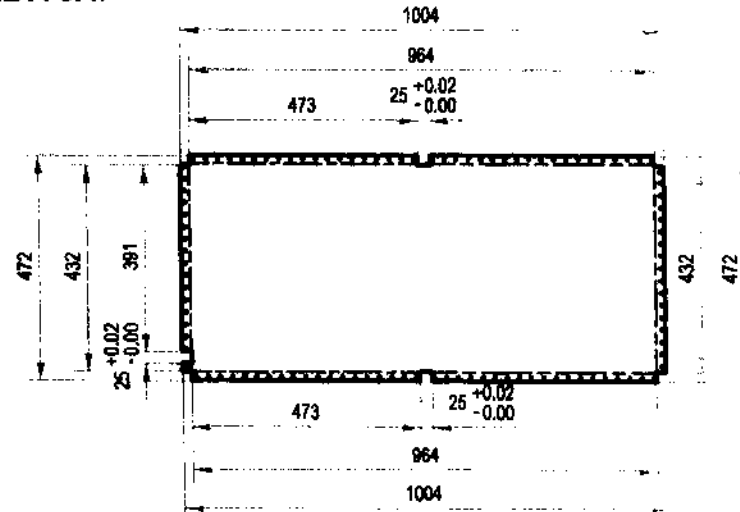

QUANTITY: 2

FLAT PATTERN: GALVANIZED SHEET GAUGE #18, PAINTED

Use 3/16" blind rivet  
spaced @ 1" O.C.



TECHNICAL  
EDUCATION AND  
SKILLS  
DEVELOPMENT  
AUTHORITY

PROJECT TITLE:  
**MOBILE TRAINING  
LABORATORY**

DRAWN BY: JPA Scale: 1:15 Sheet No.:

PRODUCED BY AN AUTODESK EDUCATIONAL PRODUCT

PRODUCED BY AN AUTODESK EDUCATIONAL PRODUCT

DETAIL A-5.1:

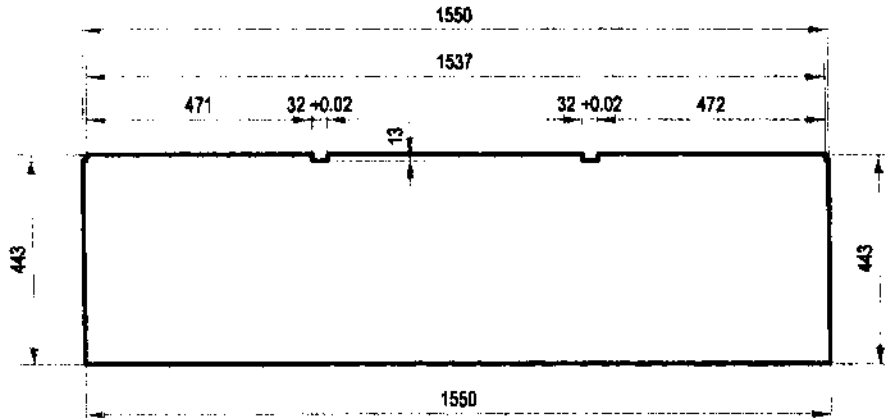

QUANTITY: 1

DETAIL A-5.3:

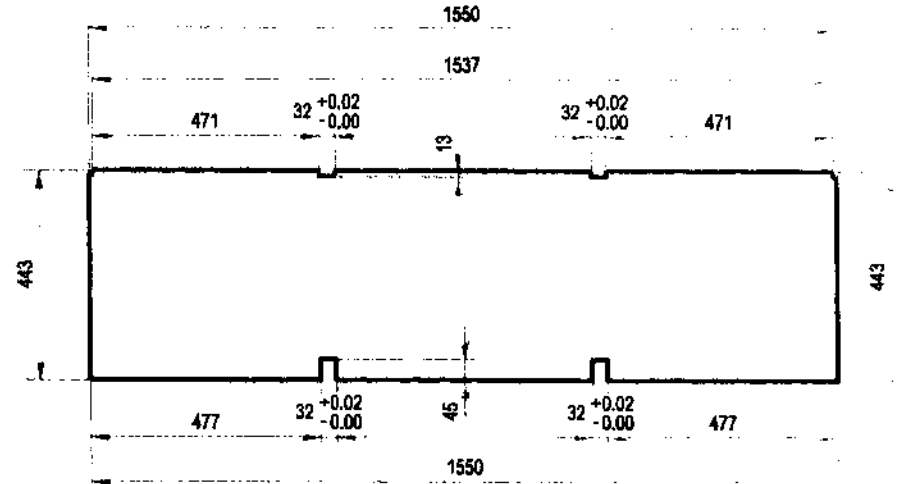

QUANTITY: 2

DETAIL A-5.2:

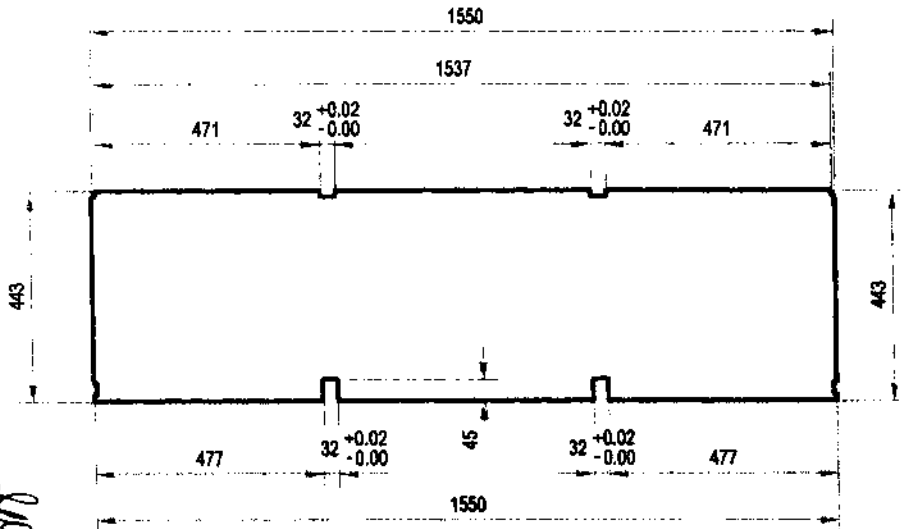

QUANTITY: 6

GALVANIZED SHEET GAUGE #18, PAINTED

DETAIL A-5.4:

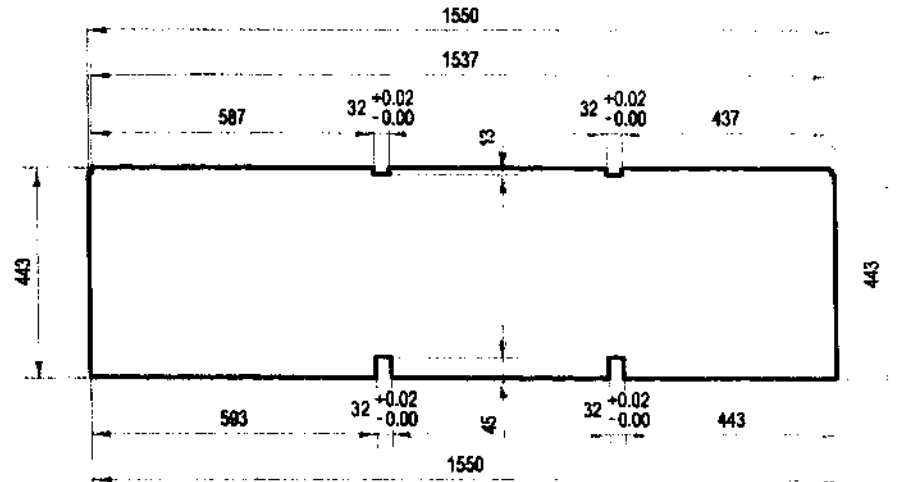

QUANTITY: 1



TECHNICAL  
EDUCATION AND  
SKILLS  
DEVELOPMENT  
AUTHORITY

PROJECT TITLE:  
**MOBILE TRAINING  
LABORATORY**

DRAWN BY: JFA | CONTROL: 444 | SHEET NO.:

PRODUCED BY AN AUTODESK EDUCATIONAL PRODUCT

PRODUCED BY AN AUTODESK EDUCATIONAL PRODUCT

MTL BOX COVER FRAME, SIDEWAY SWING

NO.	MATERIAL	LENGTH, mm	Qty.
1	Gauge #18 G.I. sheet	1,009 x 835	2
2	1" x 1" x 1.5 mm square tube	968.25	4
3	1" x 1" x 1.5 mm square tube	928.25	2
4	1" x 1" x 1.5 mm square tube	793.65	4
5	1" x 1" x 1.5 mm square tube	369.825	8
6	2" x 2mm piano hinge	968	2
TOTAL			22

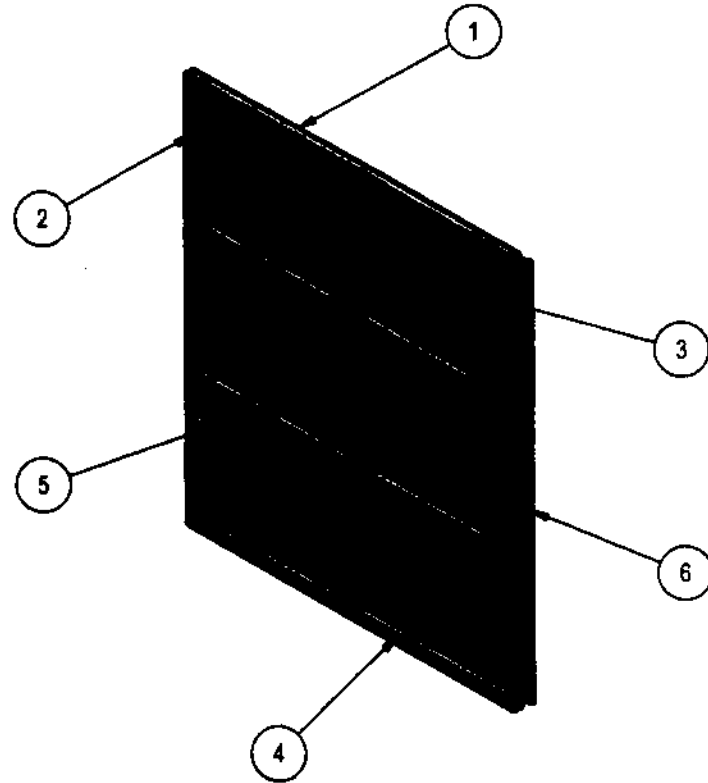

MTL DOOR FRAME

	TECHNICAL EDUCATION AND SKILLS DEVELOPMENT AUTHORITY	PROJECT TITLE: <b>MOBILE TRAINING LABORATORY</b>
	DRAWN BY: JPA    Scale: 1:15    Sheet No.:	

PRODUCED BY AN AUTODESK EDUCATIONAL PRODUCT

PRODUCED BY AN AUTODESK EDUCATIONAL PRODUCT

*Handwritten initials and marks*

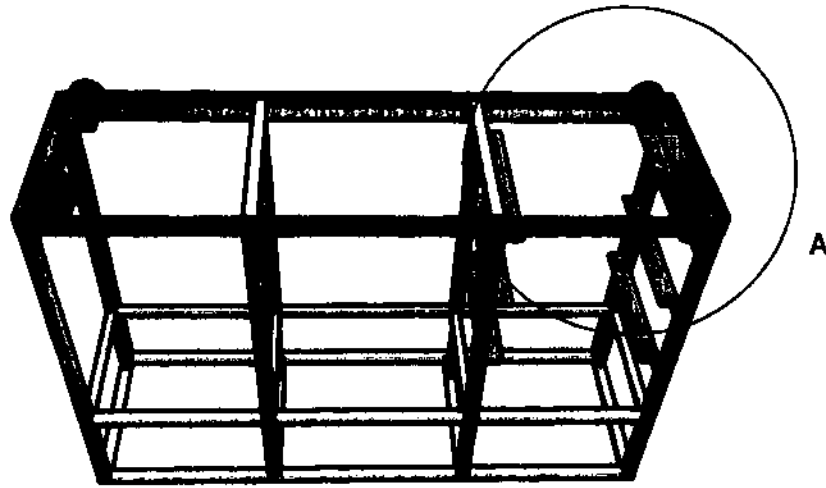

A ( 1 : 10 )

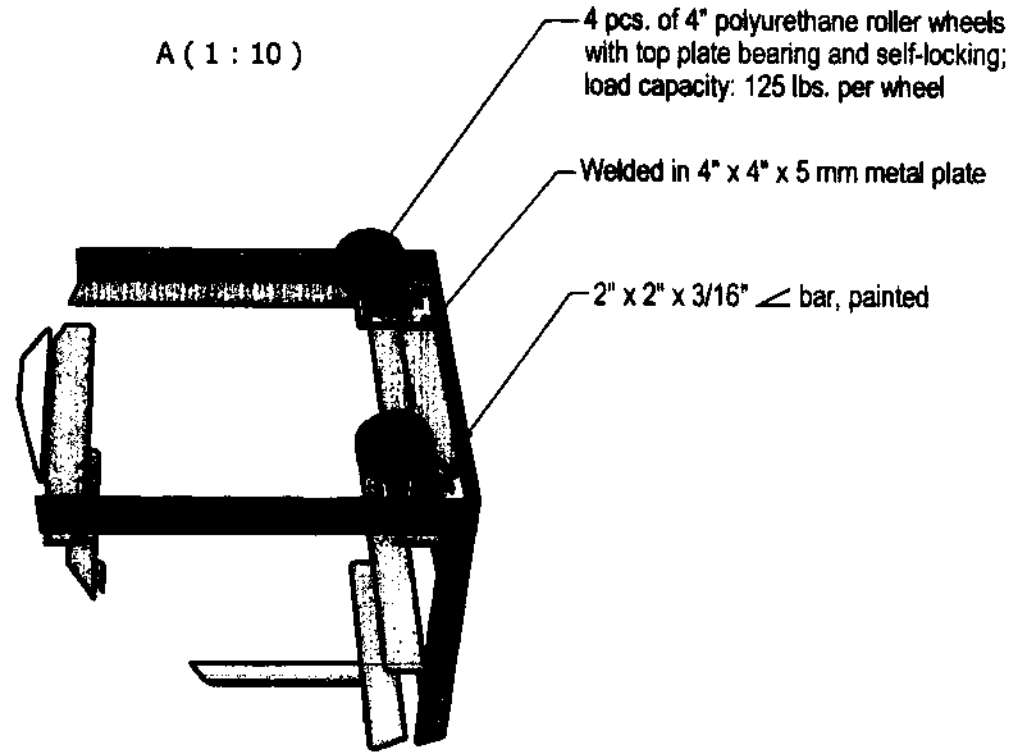

4 pcs. of 4" polyurethane roller wheels  
with top plate bearing and self-locking;  
load capacity: 125 lbs. per wheel

Welded in 4" x 4" x 5 mm metal plate

2" x 2" x 3/16"  $\angle$  bar, painted

*Handwritten initials and notes:*  
2/8  
2/8

	TECHNICAL EDUCATION AND SKILLS DEVELOPMENT AUTHORITY	PROJECT TITLE: <b>MOBILE TRAINING LABORATORY</b>
	DRAMAN BY: JPA	Scale: 1:20



DETAIL F: RUBBER DOOR SEAL

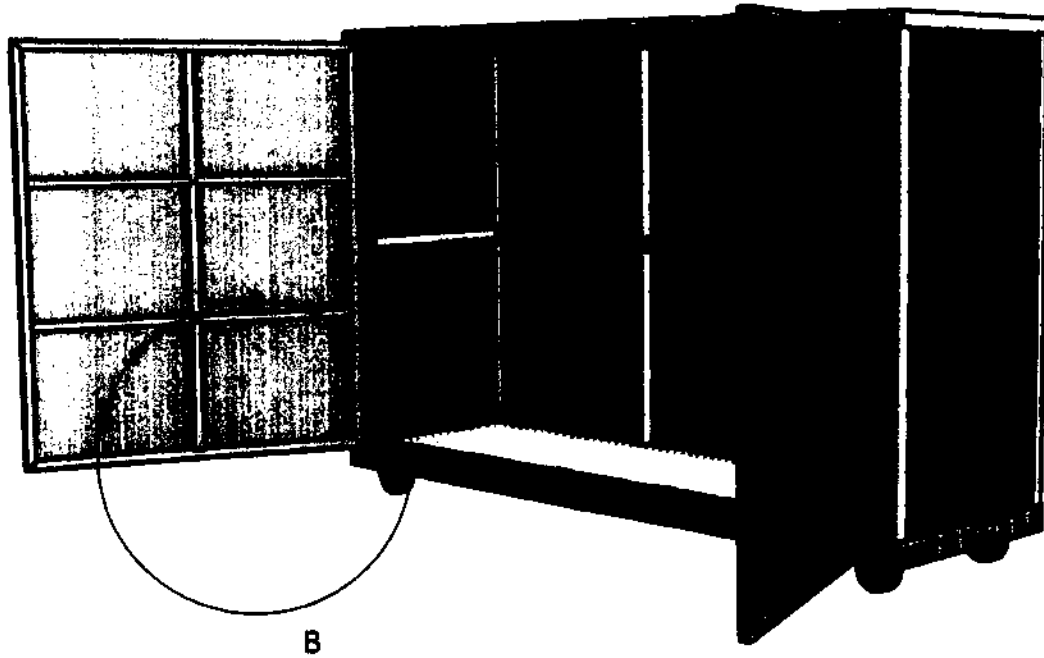

B ( 1:10 )

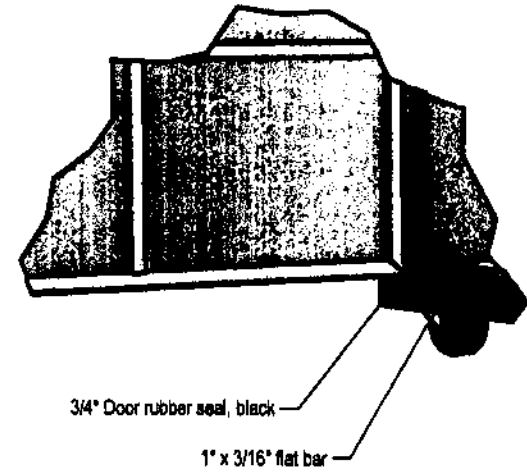

PRODUCED BY AN AUTODESK EDUCATIONAL PRODUCT

PRODUCED BY AN AUTODESK EDUCATIONAL PRODUCT

0015  
R  
M

	TECHNICAL EDUCATION AND SKILLS DEVELOPMENT AUTHORITY	PROJECT TITLE: <b>MOBILE TRAINING LABORATORY</b>	
		DRAWN BY: JPA	Scale: 1:25

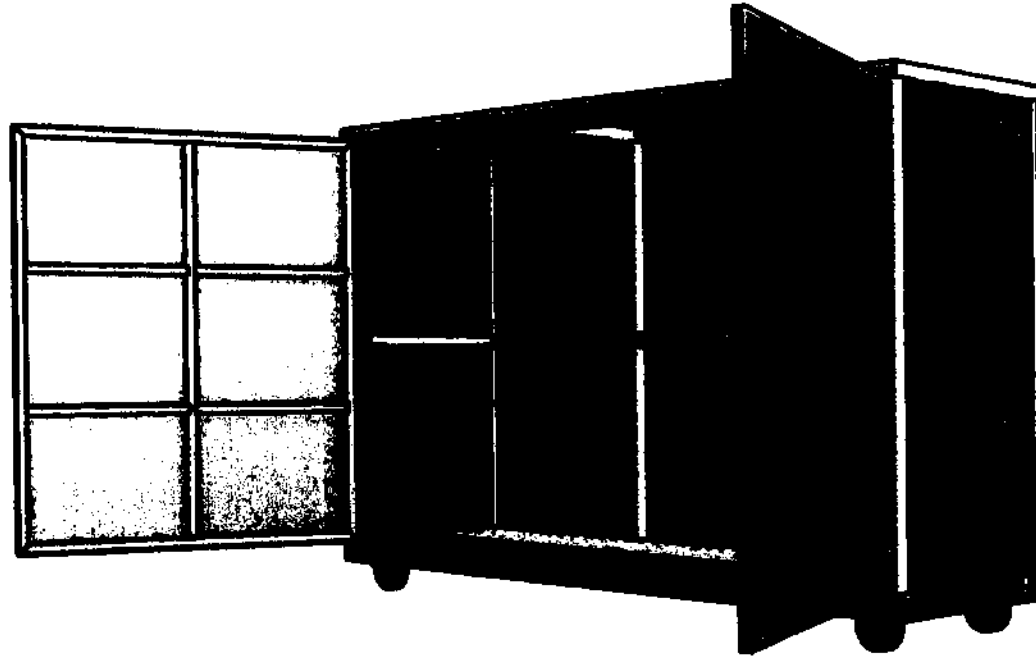

Include 2-sides metal handle  
and lock with padlock for the  
door (not shown in the drawing)

PRODUCED BY AN AUTODESK EDUCATIONAL PRODUCT

PRODUCED BY AN AUTODESK EDUCATIONAL PRODUCT

01-6  
1/15

SA



TECHNICAL  
EDUCATION AND  
SKILLS  
DEVELOPMENT  
AUTHORITY

PROJECT TITLE:  
**MOBILE TRAINING  
LABORATORY**

DRAWN BY: JPA

Scale: 1:15

Sheet No.:  
1/

**COMPARATIVE TECHNICAL SPECIFICATION**

TESDA'S SPECIFICATIONS			BIDDER'S SPECIFICATIONS	
No.	Item	Specifications	Item/Brand/Model	Specifications
Lot 2	Appliance Repair NC II with Toolbox  MTL Box No. 2	Please refer to the attached drawing		

Name of Bidder: \_\_\_\_\_

Name and Signature of Authorized Representative: \_\_\_\_\_

Position/Designation: \_\_\_\_\_

Date: \_\_\_\_\_

*Handwritten marks:*  

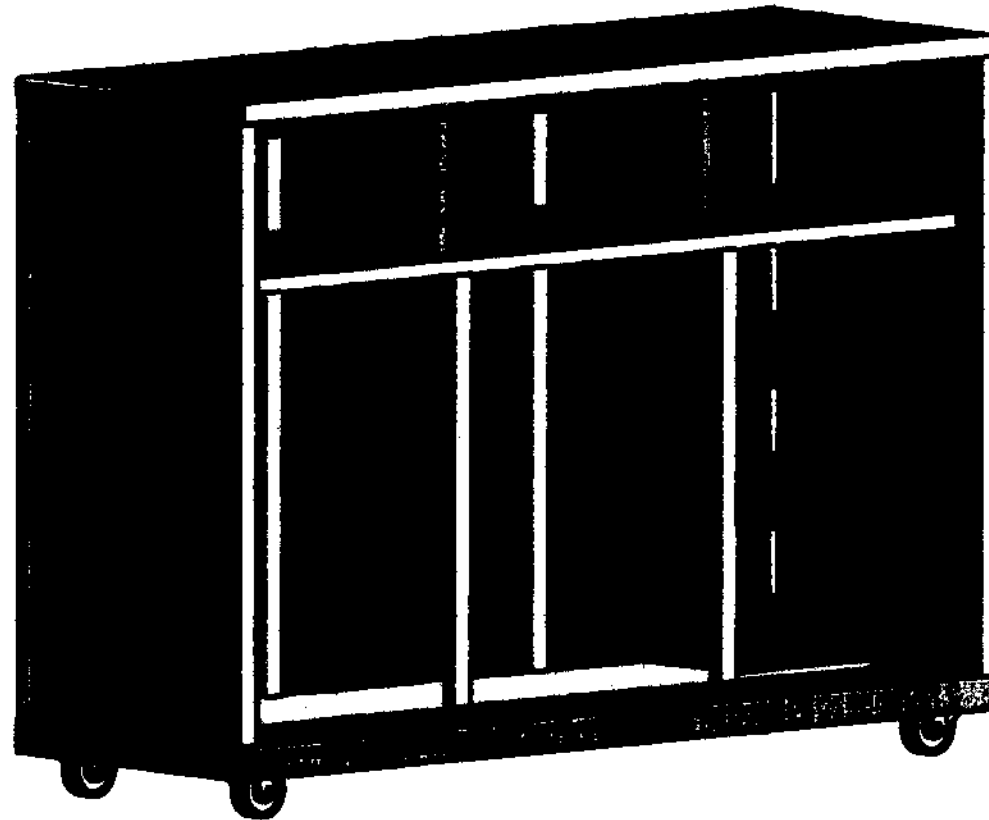
**MTL BOX NO. 2**  
**(APPLIANCE REPAIR)**  
**QUANTITY:**  
(The door is not shown in the drawing)

*Handwritten initials: JST*

	TECHNICAL EDUCATION AND SKILLS DEVELOPMENT AUTHORITY		PROJECT TITLE: <b>MOBILE TRAINING LABORATORY</b>
	DRAWN BY: JPA	Scale: 1:11	Sheet No.: 1 /

PRODUCED BY AN AUTODESK EDUCATIONAL PRODUCT

PRODUCED BY AN AUTODESK EDUCATIONAL PRODUCT

MTL BOX 2 FRAME			
NO.	MATERIAL	LENGTH, mm	Qty.
1	2" x 2" x 3/16" angle bar	1,600.00	2
2	2" x 2" x 3/16" angle bar	500.00	2
3	1 1/4" x 1 1/4" x 2 mm square tube	493.65	2
4	1 1/4" x 1 1/4" x 2 mm square tube	968.25	6
5	1 1/4" x 1 1/4" x 2 mm square tube	1,600.00	2
6	1 1/4" x 1 1/4" x 2 mm square tube	500.00	2
7	1 1/4" x 1 1/4" x 2 mm square tube	436.50	2
8	1 1/4" x 1 1/4" x 2 mm square tube	1,473.00	1
9	1 1/4" x 1 1/4" x 2 mm square tube	695.00	2
10	1" x 1" x 1.5 mm square tube	393.25	2
11	1" x 1" x 1.5 mm square tube	392.04	2
12	1" x 1" x 1.5 mm square tube	1,536.50	1
13	1" x 1" x 1.5 mm square tube	968.25	2
14	Gauge #18 GI sheet, 2" x 2" @ 90 degrees bend	431.70	6
15	3/4" x 3/4" x 1.5 mm square tube	247.04	2
TOTAL			36

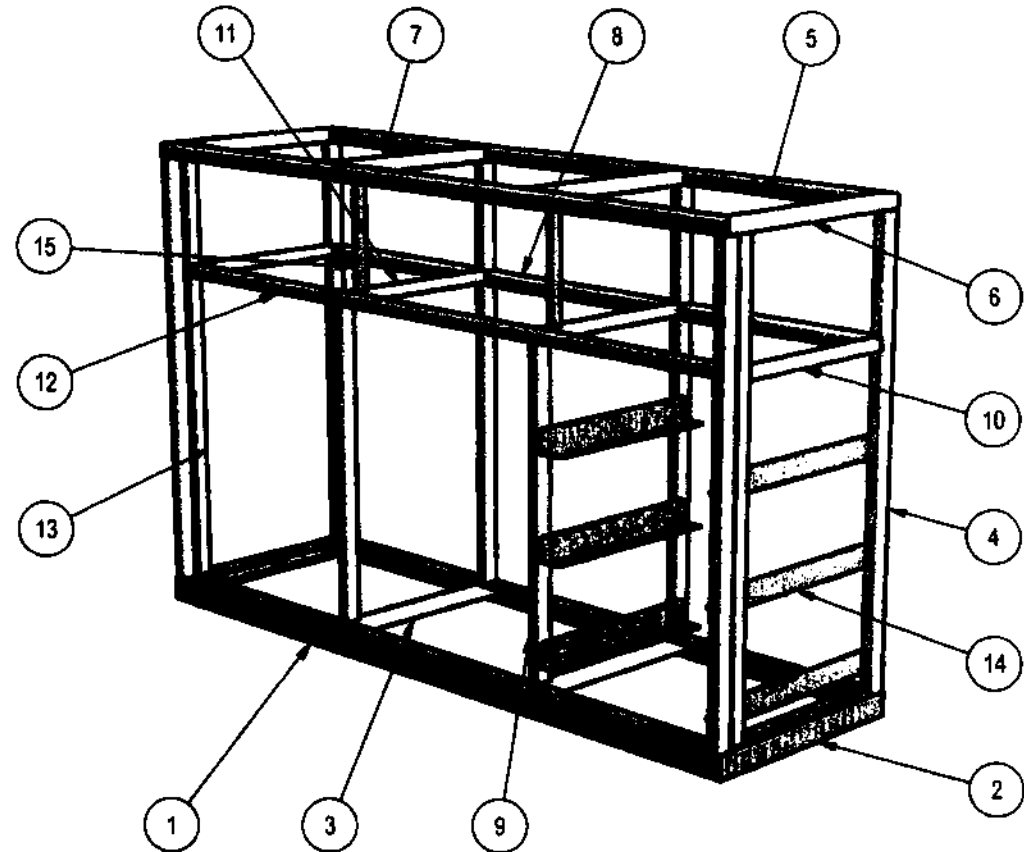

**MTL BOX NO. 2 FRAME  
(APPLIANCE REPAIR)**  
(The door is not shown in the drawing)

	<b>TECHNICAL EDUCATION AND SKILLS DEVELOPMENT AUTHORITY</b>	<b>PROJECT TITLE: MOBILE TRAINING LABORATORY</b>	
	DRAWN BY: JPA	Scale: 1:15	Sheet No.: 1 / 1

*Handwritten initials and date: JPA 1/15*

**MTL BOX NO. 2**

- ◆ All materials must be painted with anti-corrosive primer
- ◆ □ tube and ∟ bar are coated with light gray epoxy finish paint

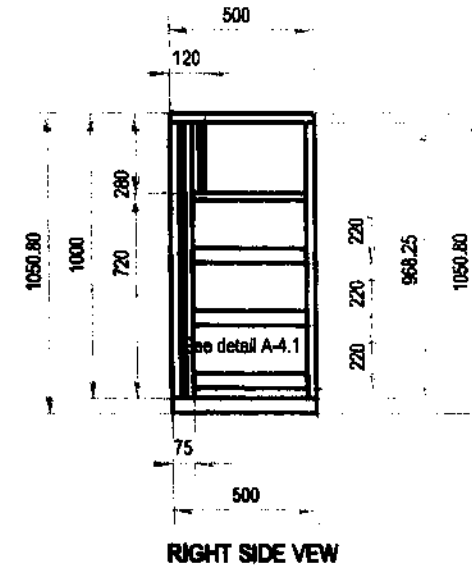
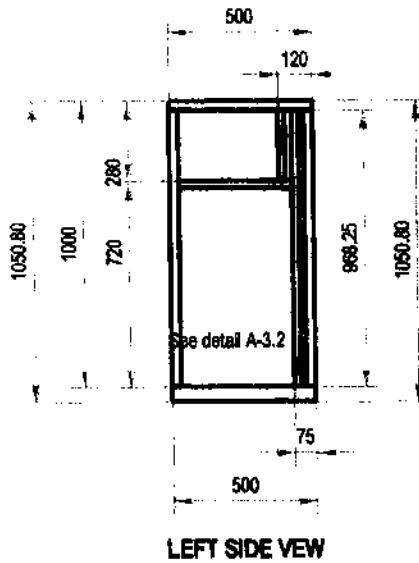
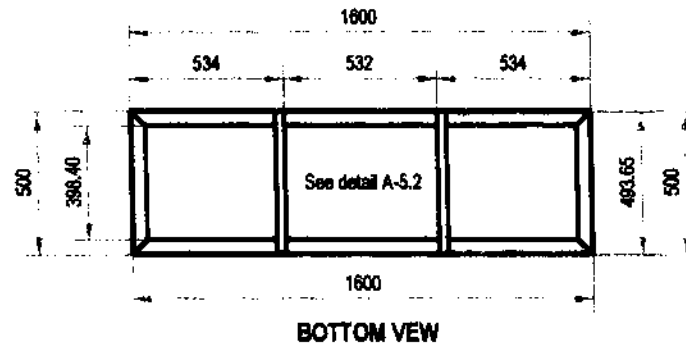
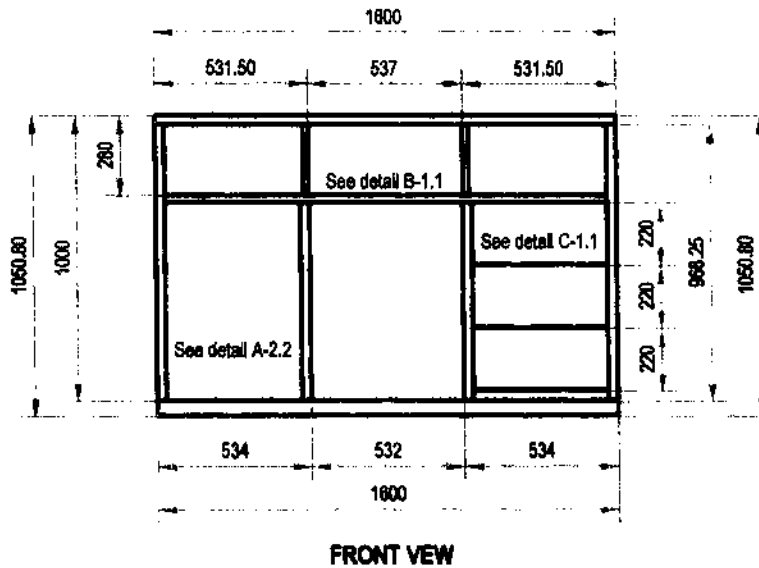
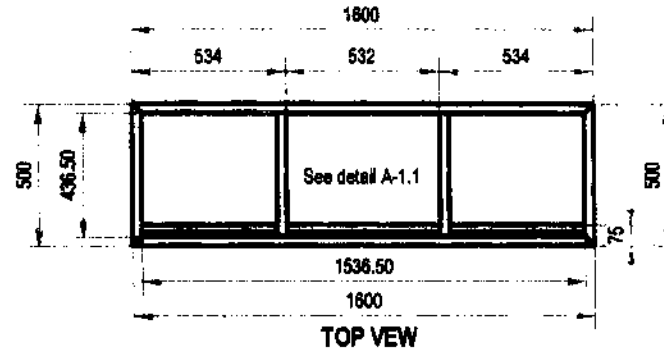

**MTL BOX NO. 2 FRAME  
(APPLIANCE REPAIR)**

(The door is not shown in the drawing)

	TECHNICAL EDUCATION AND SKILLS DEVELOPMENT AUTHORITY	PROJECT TITLE: <b>MOBILE TRAINING LABORATORY</b>
	Sheet No.:	

PRODUCED BY AN AUTODESK EDUCATIONAL PRODUCT

PRODUCED BY AN AUTODESK EDUCATIONAL PRODUCT

**DETAIL A-1.1:**

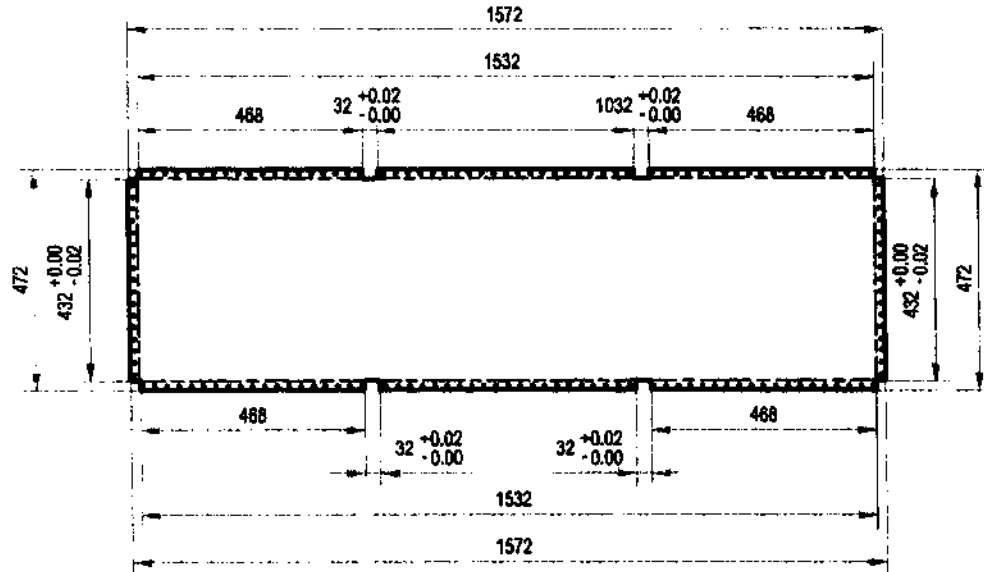

QUANTITY: 5

**DETAIL A-1.3:**

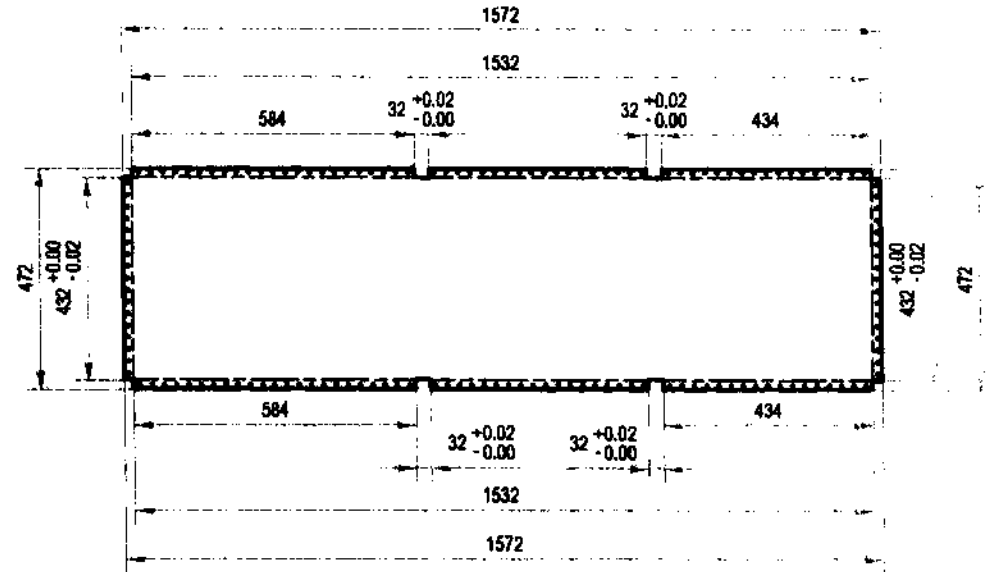

QUANTITY: 1

**DETAIL A-1.2:**

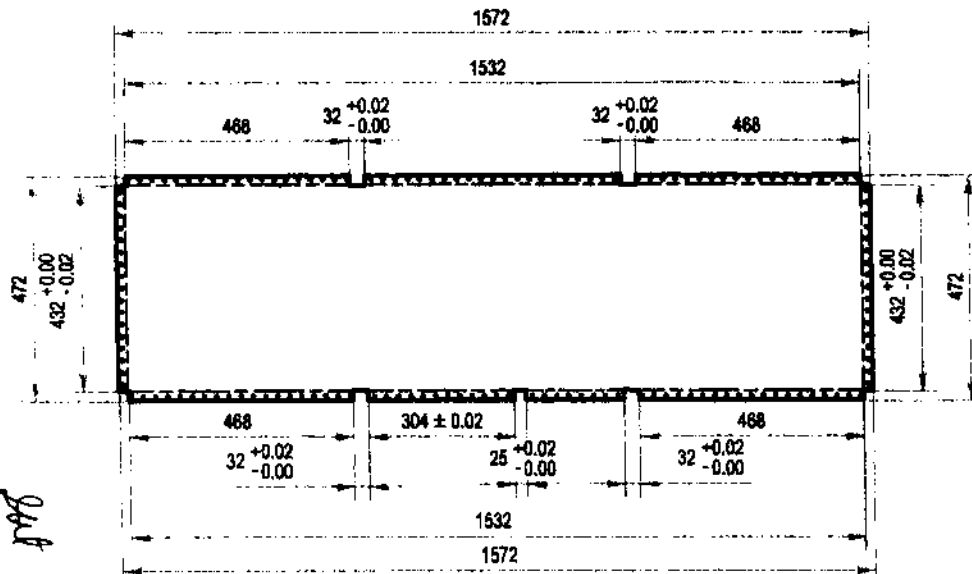

QUANTITY: 2

FLAT PATTERN: GALVANIZED SHEET GAUGE #18, PAINTED

**DETAIL A-1.4:**

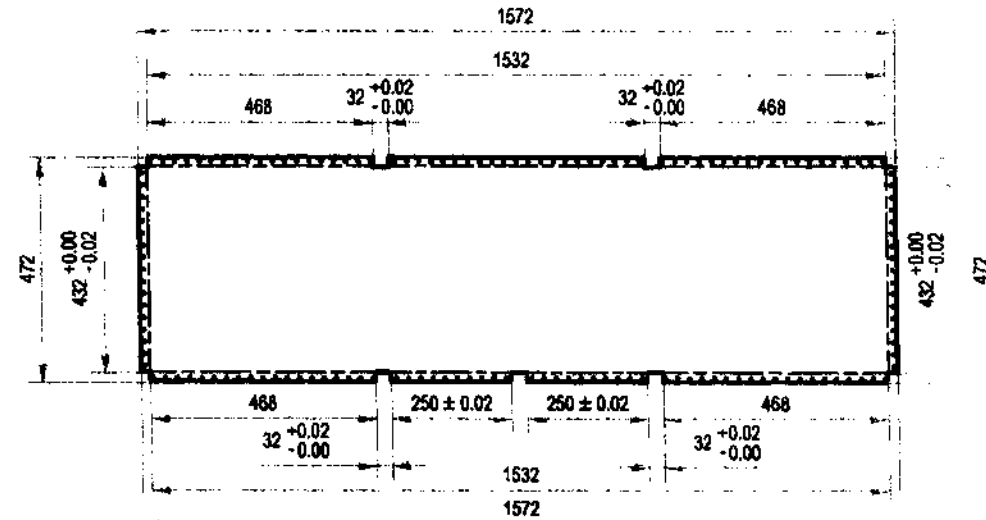

QUANTITY: 2

Use 3/16" blind rivet  
spaced @ 1" O.C.



TECHNICAL  
EDUCATION AND  
SKILLS  
DEVELOPMENT  
AUTHORITY

PROJECT TITLE:  
**MOBILE TRAINING  
LABORATORY**

Sheet No.:

DETAIL A-2.1:

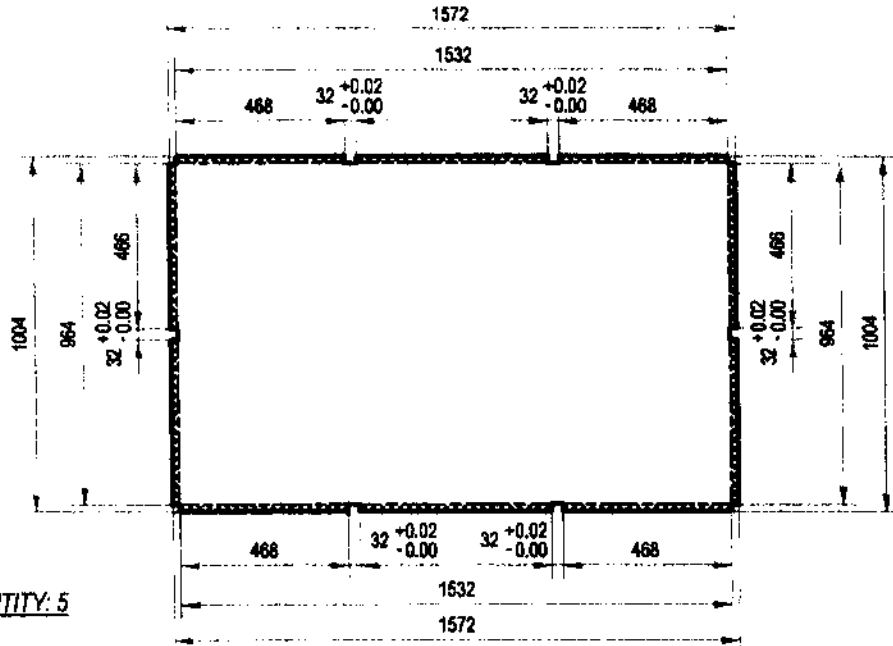

QUANTITY: 5

DETAIL A-2.3:

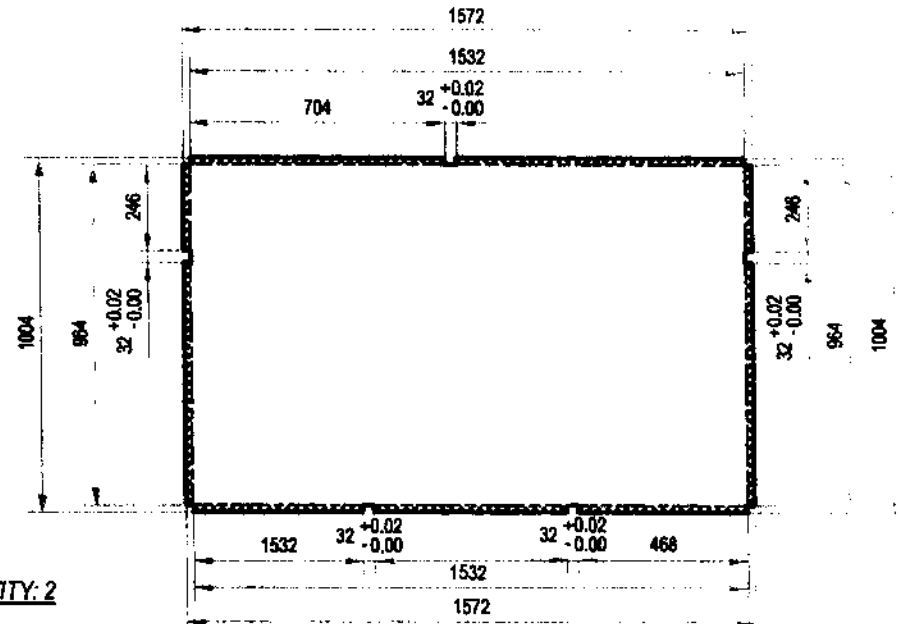

QUANTITY: 2

DETAIL A-2.2:

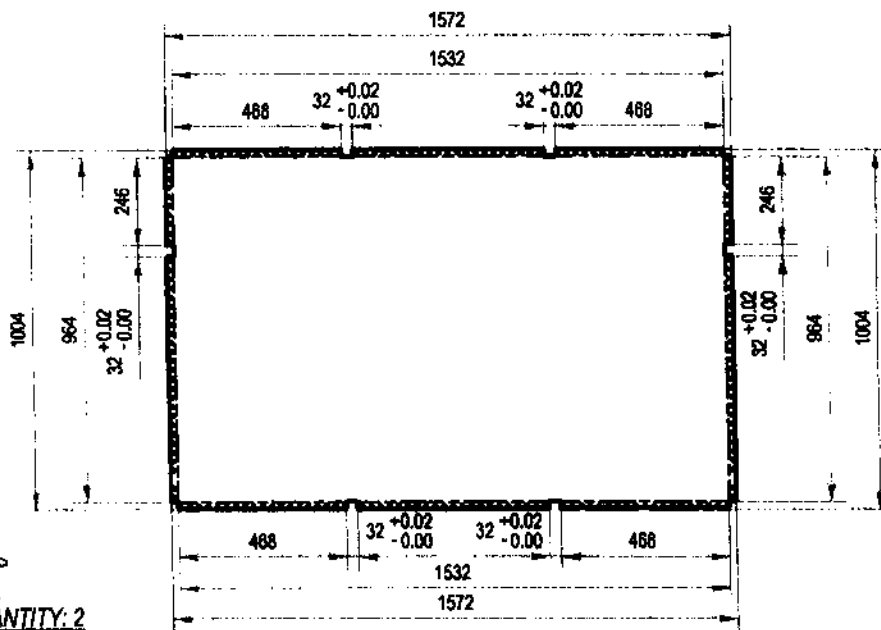

QUANTITY: 2

DETAIL A-2.4:

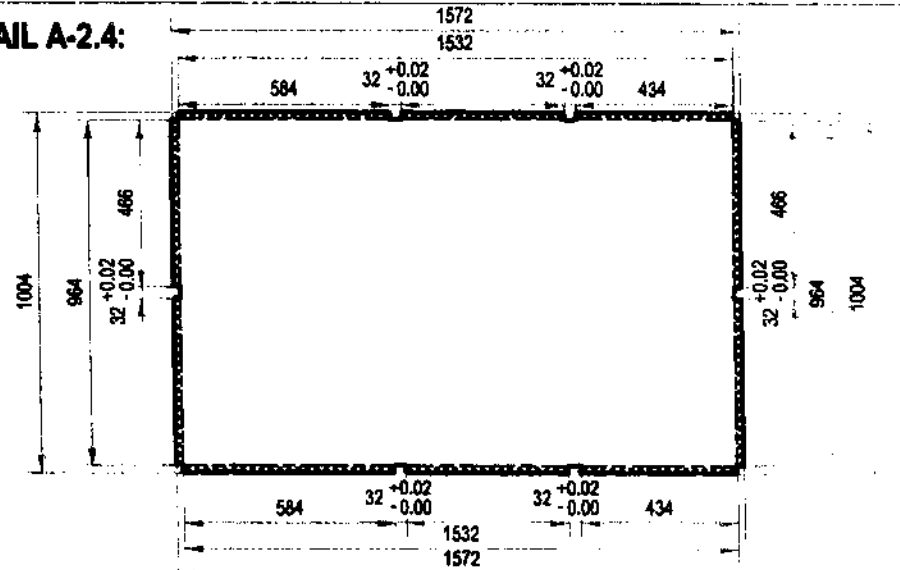

QUANTITY: 1

Use 3/8" blind rivet spaced @ 1" O.C.



TECHNICAL EDUCATION AND SKILLS DEVELOPMENT AUTHORITY

PROJECT TITLE:  
**MOBILE TRAINING LABORATORY**

Sheet No.:

FLAT PATTERN: GALVANIZED SHEET GAUGE #18, PAINTED

PRODUCED BY AN AUTODESK EDUCATIONAL PRODUCT

PRODUCED BY AN AUTODESK EDUCATIONAL PRODUCT



DETAIL A-3.1:

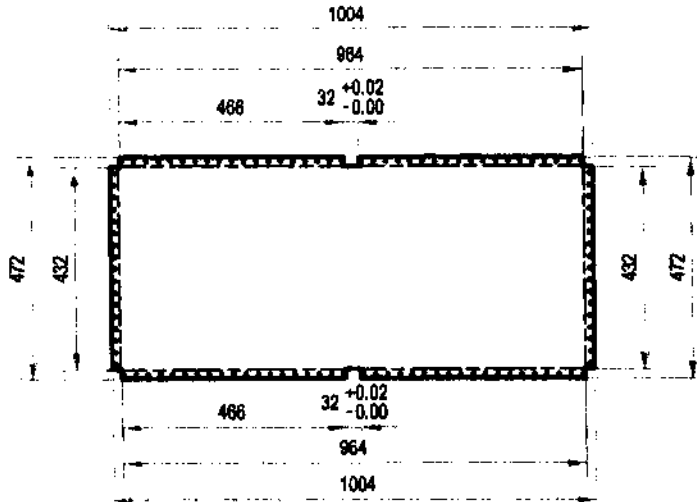

QUANTITY: 5

DETAIL A-3.3:

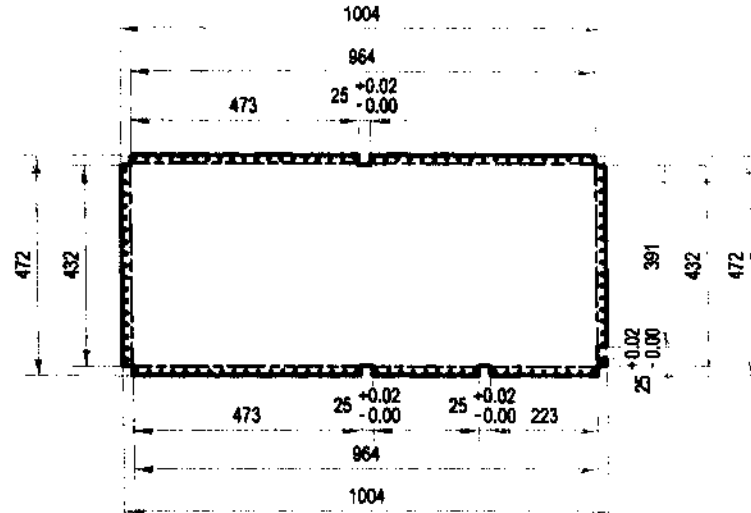

QUANTITY: 1

DETAIL A-3.2:

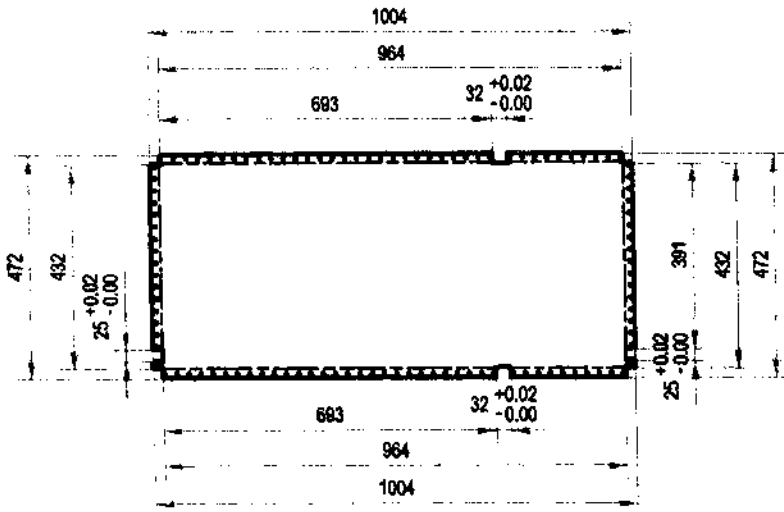

QUANTITY: 4

DETAIL A-3.4:

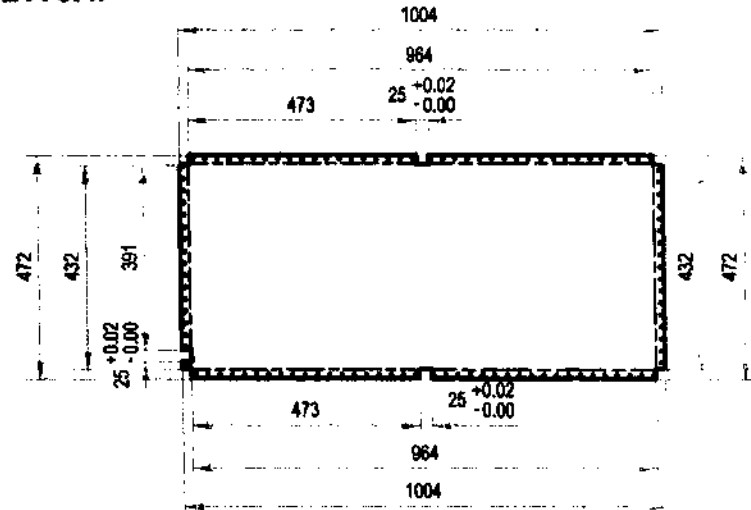

QUANTITY: 2

FLAT PATTERN: GALVANIZED SHEET GAUGE #18, PAINTED

Use 3/16" blind rivet spaced @ 1" O.C.



TECHNICAL EDUCATION AND SKILLS DEVELOPMENT AUTHORITY

PROJECT TITLE: MOBILE TRAINING LABORATORY

Scale: 1:15

PRODUCED BY AN AUTODESK EDUCATIONAL PRODUCT

PRODUCED BY AN AUTODESK EDUCATIONAL PRODUCT

DETAIL A-4.1:

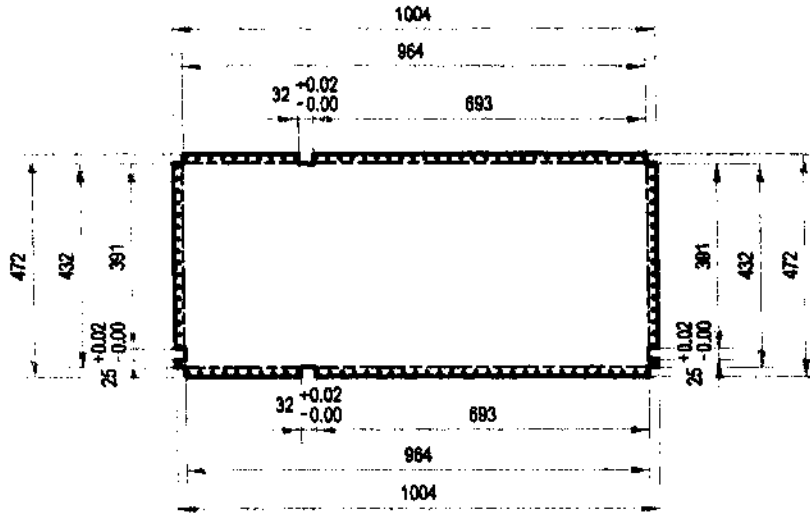

QUANTITY: 4

DETAIL A-4.2:

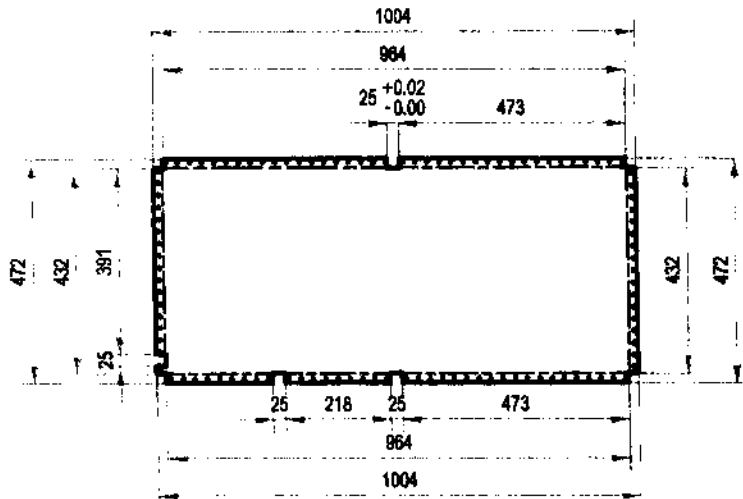

QUANTITY: 2

DETAIL A-4.3:

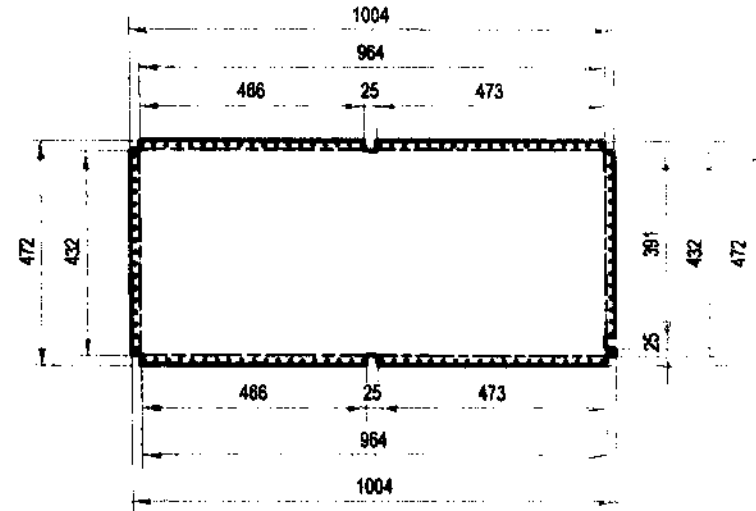

QUANTITY: 2

FLAT PATTERN: GALVANIZED SHEET GAUGE #18, PAINTED

Use 3/16" blind rivet spaced @ 1" O.C.



PROJECT TITLE: MOBILE TRAINING LABORATORY

DRAWN BY: JPA Scale: 1:15 Sheet No.: 1/

DETAIL A-5.1:

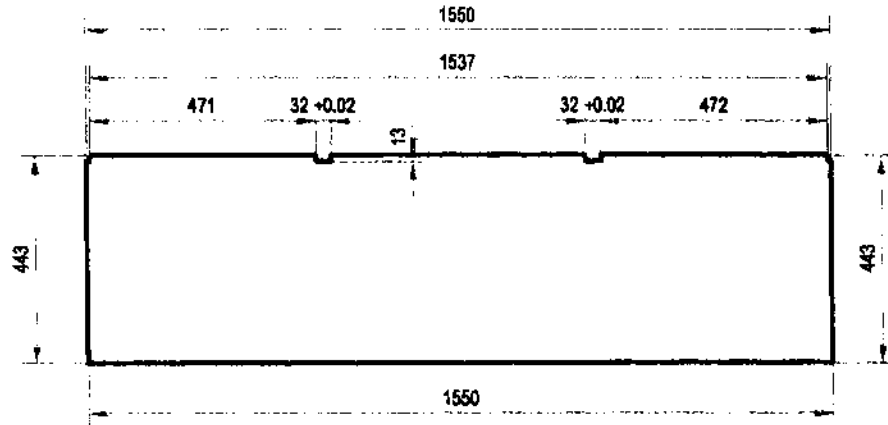

QUANTITY: 1

DETAIL A-5.3:

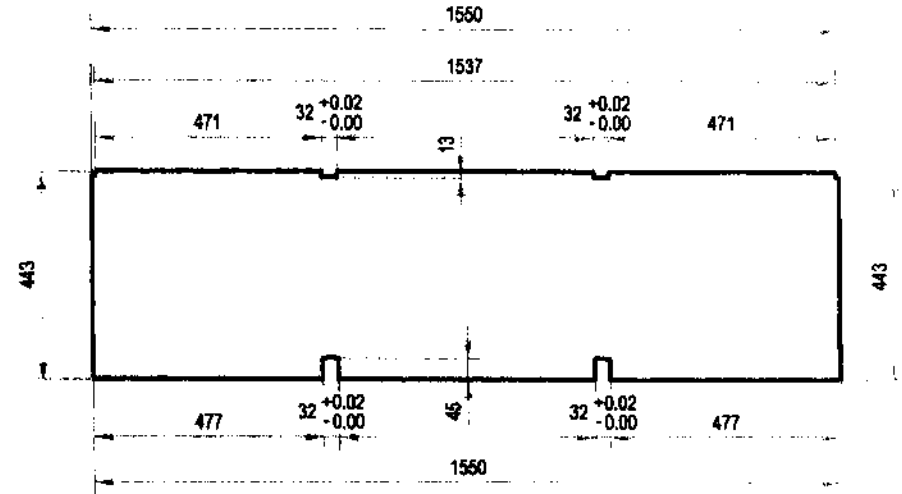

QUANTITY: 2

DETAIL A-5.2:

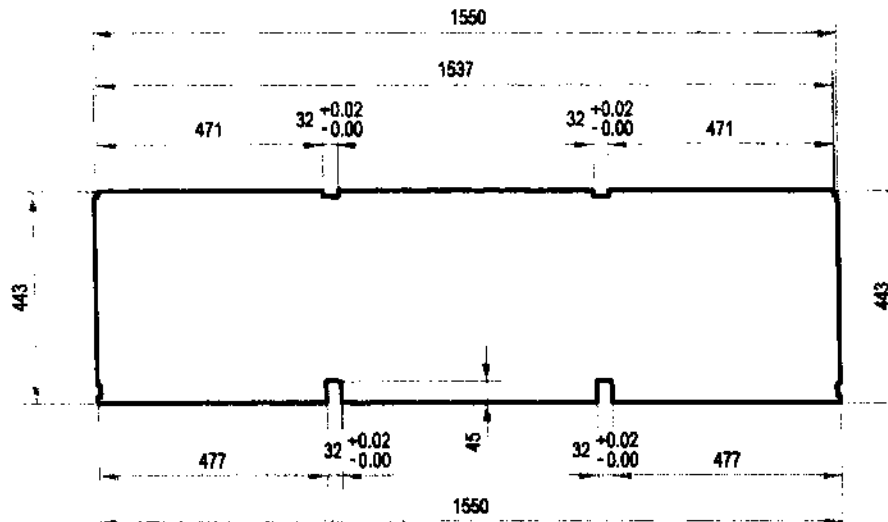

QUANTITY: 6

DETAIL A-5.4:

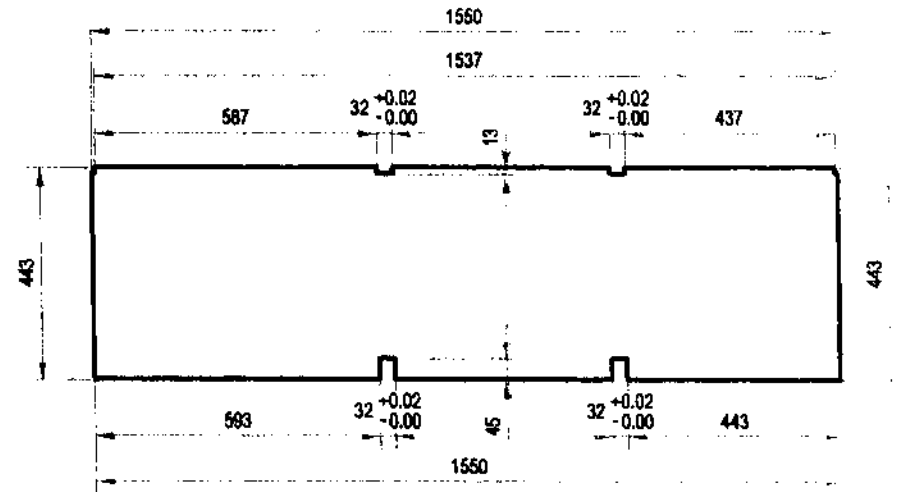

QUANTITY: 1

GALVANIZED SHEET GAUGE #18, PAINTED



TECHNICAL  
EDUCATION AND  
SKILLS  
DEVELOPMENT  
AUTHORITY

PROJECT TITLE:  
**MOBILE TRAINING  
LABORATORY**

DRAWN BY: JPA Scale: 1:15 Sheet No.: 1/1

PRODUCED BY AN AUTODESK EDUCATIONAL PRODUCT

PRODUCED BY AN AUTODESK EDUCATIONAL PRODUCT

DETAIL B-1.1:

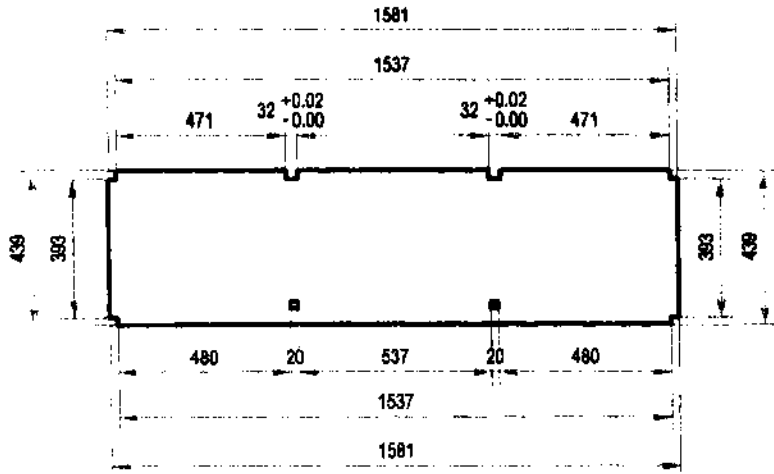

QUANTITY: 2

DETAIL B-1.3:

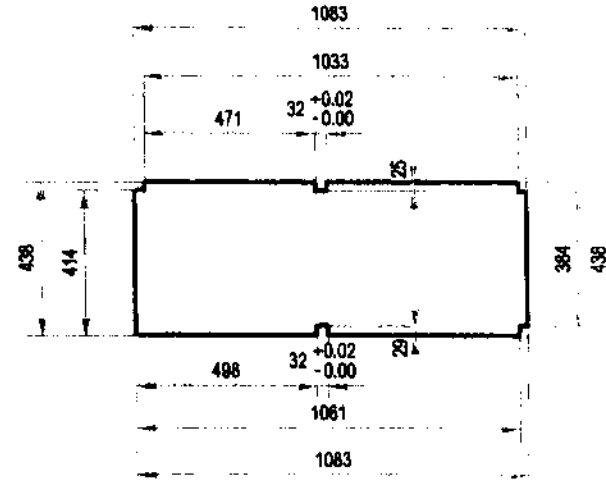

QUANTITY: 1

DETAIL B-1.2:

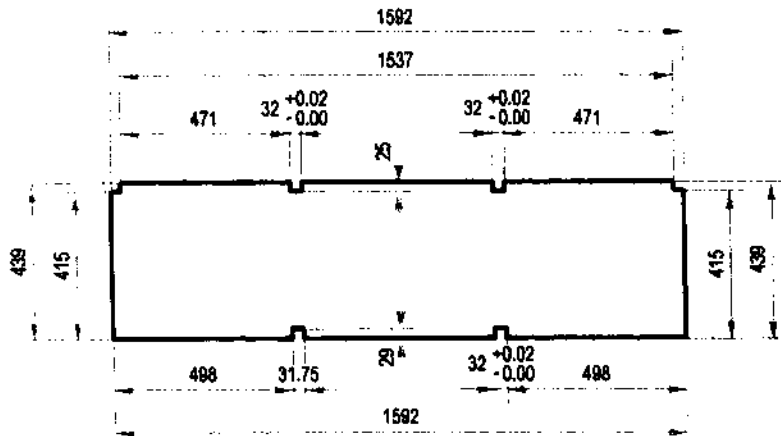

QUANTITY: 1

DETAIL B-1.4:

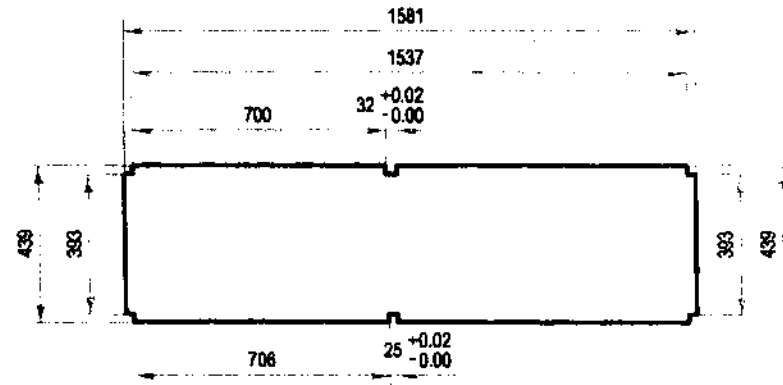

QUANTITY: 2

GALVANIZED SHEET GAUGE #18, PAINTED



TECHNICAL  
EDUCATION AND  
SKILLS  
DEVELOPMENT  
AUTHORITY

PROJECT TITLE:  
**MOBILE TRAINING  
LABORATORY**

DRAWN BY: JPA Scale: 1:20

PRODUCED BY AN AUTODESK EDUCATIONAL PRODUCT

PRODUCED BY AN AUTODESK EDUCATIONAL PRODUCT

**DETAIL C-1.1:**

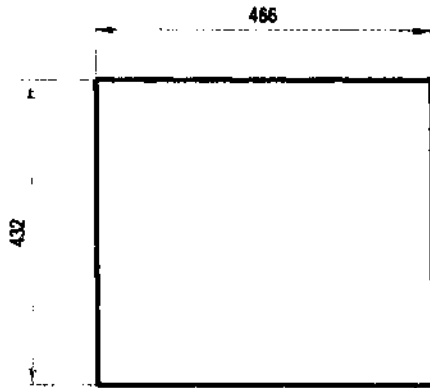

QUANTITY: 15

**DETAIL C-1.3:**

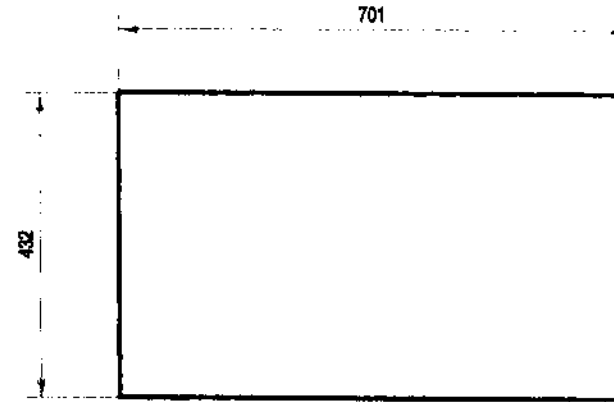

QUANTITY: 2

**DETAIL C-1.2:**

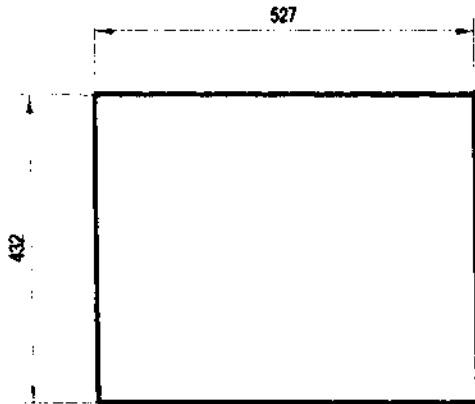

QUANTITY: 9

**DETAIL D-1.1:**

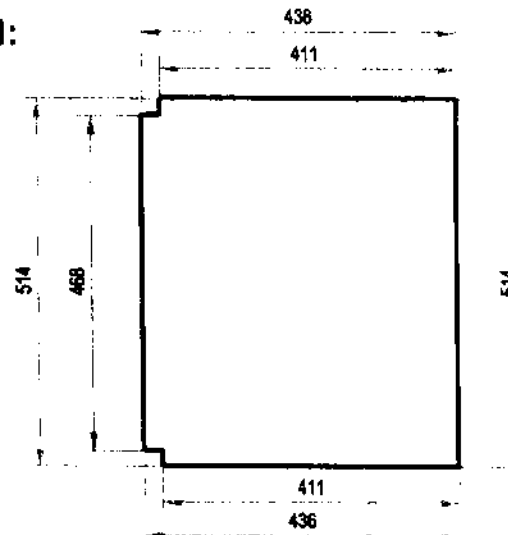

QUANTITY: 1

GALVANIZED SHEET GAUGE #18, PAINTED



TECHNICAL  
EDUCATION AND  
SKILLS  
DEVELOPMENT  
AUTHORITY

PROJECT TITLE:  
**MOBILE TRAINING  
LABORATORY**

DRAWN BY: JPA Scale: 1:10 Sheet No: 1.1

PRODUCED BY AN AUTODESK EDUCATIONAL PRODUCT

PRODUCED BY AN AUTODESK EDUCATIONAL PRODUCT

*Handwritten signature/initials*

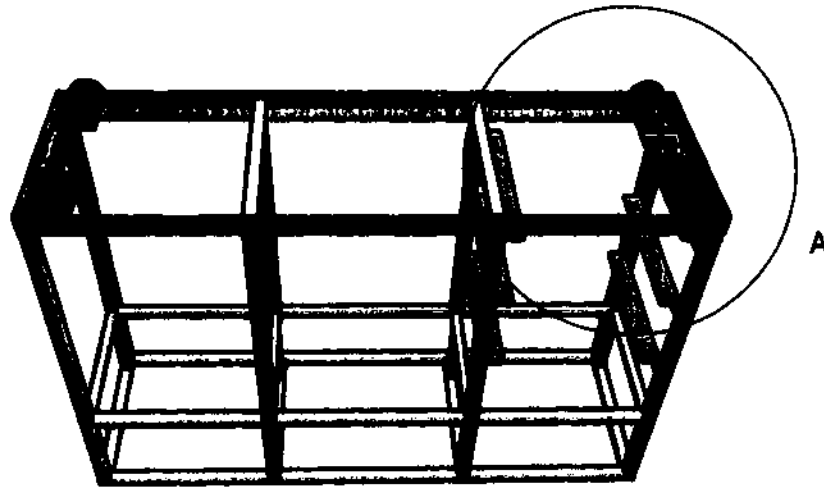

A ( 1 : 10 )

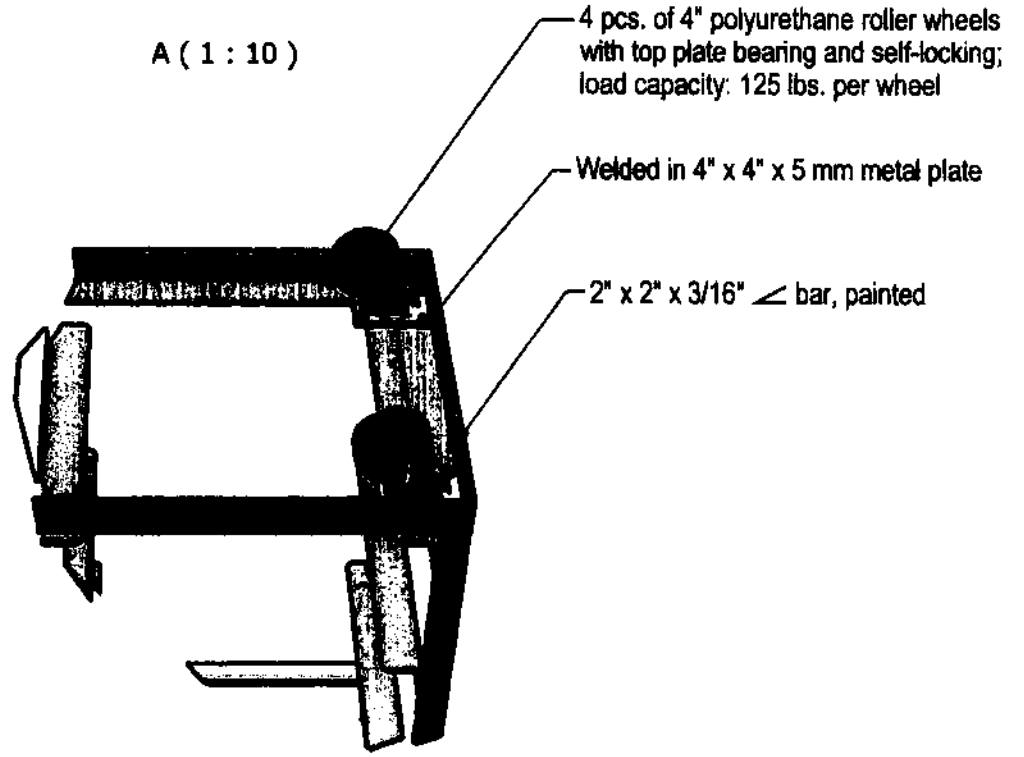

Handwritten initials and a signature.

	TECHNICAL EDUCATION AND SKILLS DEVELOPMENT AUTHORITY	PROJECT TITLE: <b>MOBILE TRAINING LABORATORY</b>
	DESIGN BY: JPA	Scale: 1:20

DETAIL F: RUBBER DOOR SEAL

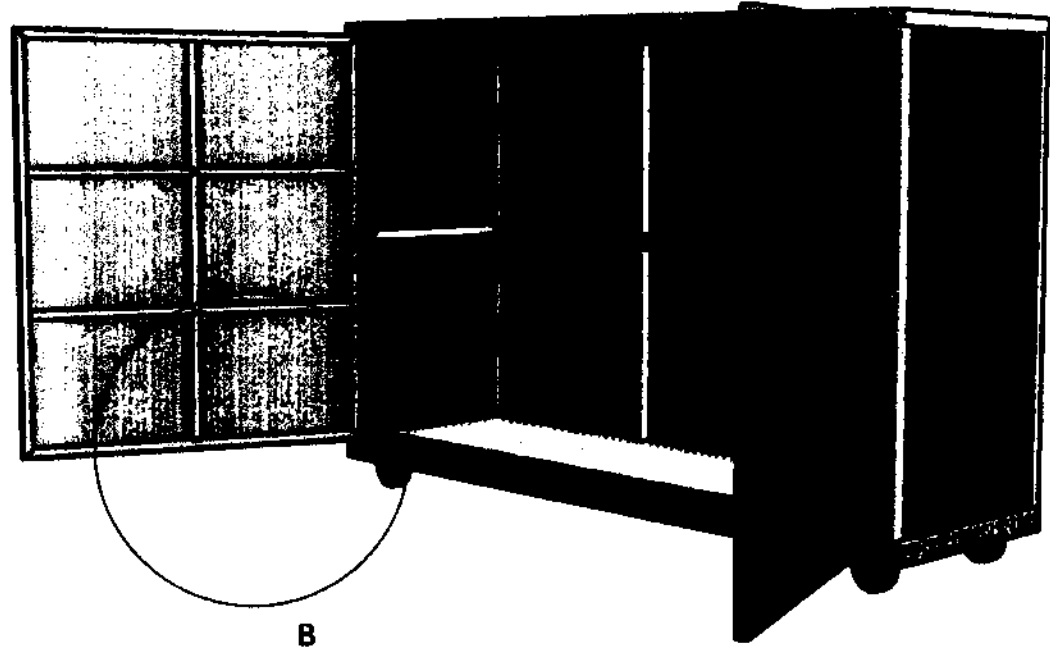

B ( 1:10 )

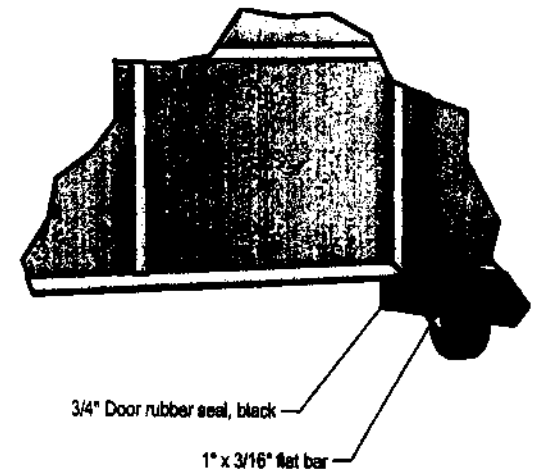

PRODUCED BY AN AUTODESK EDUCATIONAL PRODUCT

PRODUCED BY AN AUTODESK EDUCATIONAL PRODUCT

*Handwritten initials and notes:*  
KJH  
FHS

	TECHNICAL EDUCATION AND SKILLS DEVELOPMENT AUTHORITY	PROJECT TITLE: <b>MOBILE TRAINING LABORATORY</b>
	<small>Drawn by: JKH</small>	<small>Scale: 1:25</small>

MTL BOX COVER FRAME, SIDEWAY SWING

NO.	MATERIAL	LENGTH, mm	Qty.
1	Gauge #18 G.I. sheet	1,009 x 835	2
2	1" x 1" x 1.5 mm square tube	968.25	4
3	1" x 1" x 1.5 mm square tube	928.25	2
4	1" x 1" x 1.5 mm square tube	793.65	4
5	1" x 1" x 1.5 mm square tube	369.825	8
6	2" x 2mm piano hinge	968	2
TOTAL			22

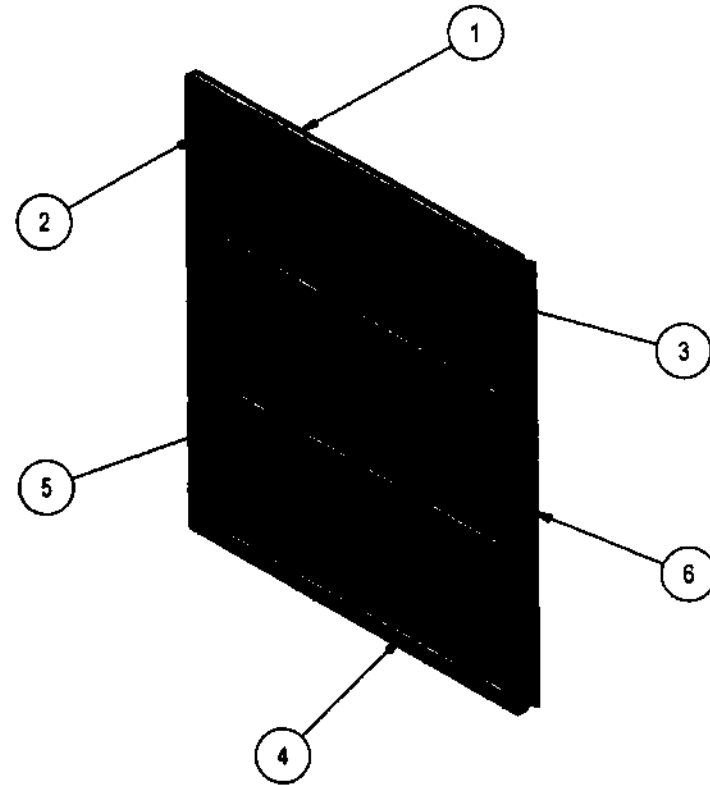

MTL DOOR FRAME

 <p>TECHNICAL EDUCATION AND SKILLS DEVELOPMENT AUTHORITY</p>	<p>PROJECT TITLE: <b>MOBILE TRAINING LABORATORY</b></p>
	<p>DRAWN BY: JPA    Scale: 1:15    Sheet No.:</p>

PRODUCED BY AN AUTODESK EDUCATIONAL PRODUCT

PRODUCED BY AN AUTODESK EDUCATIONAL PRODUCT

*Handwritten signature and initials*



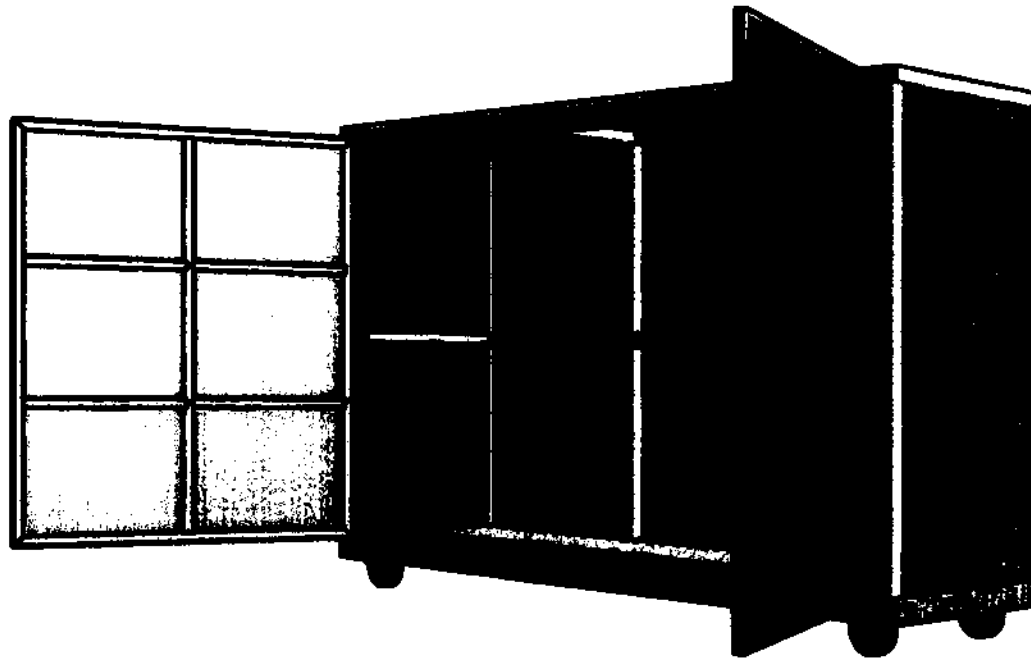

Include 2-sides metal handle  
and lock with padlock for the  
door (not shown in the drawing)

PRODUCED BY AN AUTODESK EDUCATIONAL PRODUCT

PRODUCED BY AN AUTODESK EDUCATIONAL PRODUCT

*Handwritten initials and date:*  
JW 7/20/00  
JTB

	TECHNICAL EDUCATION AND SKILLS DEVELOPMENT AUTHORITY	PROJECT TITLE: <b>MOBILE TRAINING LABORATORY</b>
	Drawn By: JTB	Scale: 1:15

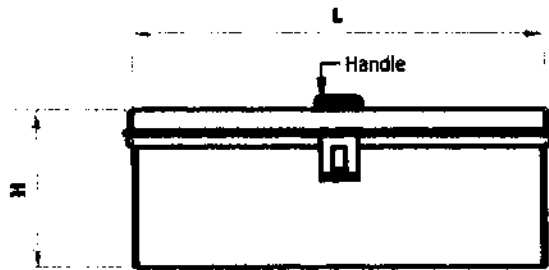

FRONT VIEW

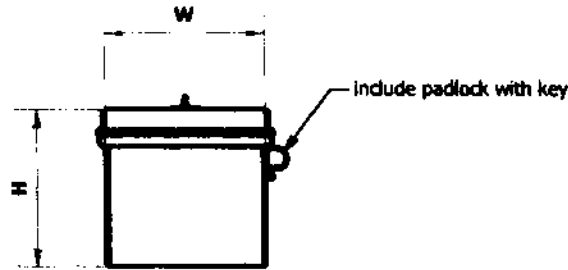

SIDE VIEW

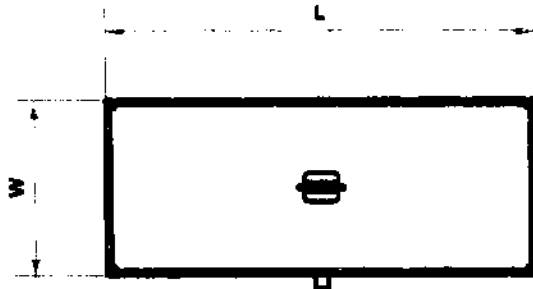

TOP VIEW

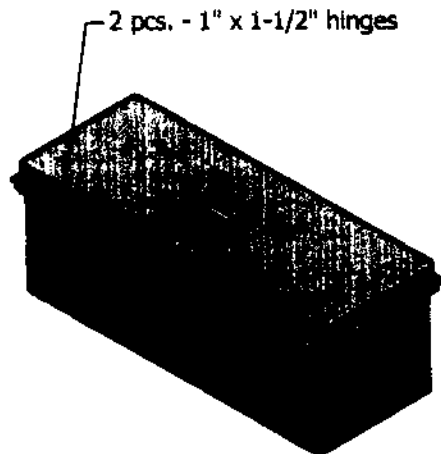

ISOMETRIC VIEW

TOOLBOX			
NO.	DIMENSION (L x	MATERIAL	NO. OF PCS. PER SET
1	18" x 7" x 7"	Small Engine Repair - G.A. #18 galvanized sheet, painted	12
3	18" x 7" x 8"	Appliance Repair -G.A. #18 galvanized sheet, painted	6
	18" x 7" x 8"	Electrical Installation and Maintenance - G.A. #18 galvanized sheet, painted	6
4	20" x 7" x 8"	Small Engine Repair - G.A. #18 galvanized sheet, painted	6
5	16" x 20" x 4-1/2"	Cookery - Plastic, white	3
6	16" x 20" x 4-1/2"	Food Processing - Plastic, white	3

PRODUCED BY AN AUTODESK EDUCATIONAL PRODUCT

PRODUCED BY AN AUTODESK EDUCATIONAL PRODUCT



TECHNICAL  
EDUCATION AND  
SKILLS  
DEVELOPMENT  
AUTHORITY

PROJECT TITLE:  
**COMPACT MOBILE UNIT**

DRAWN BY: JPA Scale: 1:8 Sheet No.: 1 / 1

**COMPARATIVE TECHNICAL SPECIFICATION**

TESDA'S SPECIFICATIONS			BIDDER'S SPECIFICATIONS	
No.	Item	Specifications	Item/Brand/Model	Specifications
Lot 3	Bread and Pastry NC II MTL Box No. 3	Please refer to the attached drawing		
	Bread and Pastry NC II MTL Box No. 4	Please refer to the attached drawing		

Name of Bidder: \_\_\_\_\_

Name and Signature of Authorized Representative: \_\_\_\_\_

Position/Designation: \_\_\_\_\_

Date: \_\_\_\_\_

*Lot 3*  
*2018*

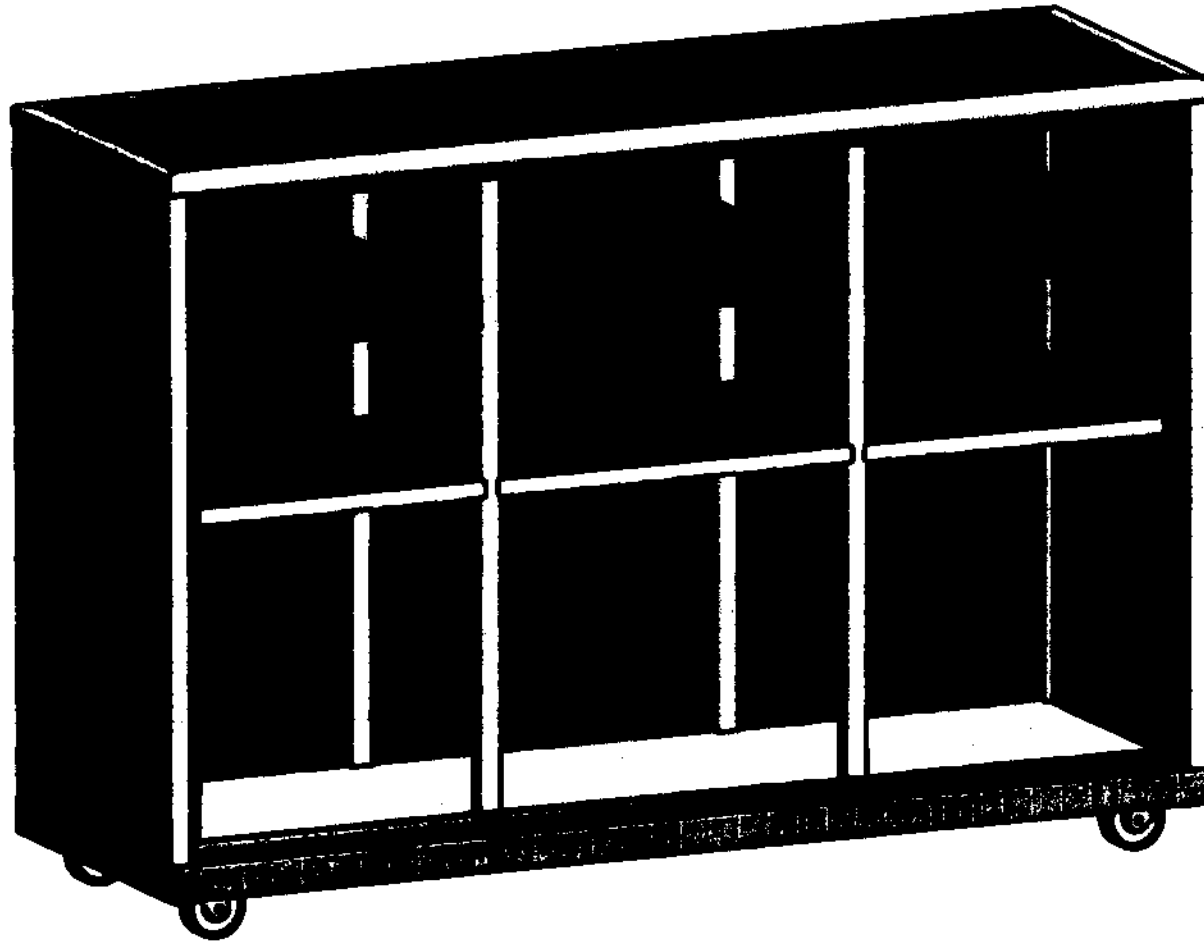

**MTL BOX NO. 3**  
**(BREAD AND PASTRY)**  
**QUANTITY:**  
(The door is not shown in the drawing)

Handwritten initials and a checkmark.

	<b>TECHNICAL EDUCATION AND SKILLS DEVELOPMENT AUTHORITY</b>	<b>PROJECT TITLE:</b> <b>MOBILE TRAINING LABORATORY</b>
	<small>Drawn by: JPA</small>	<small>Scale: 1:10</small>

MTL BOX 3 FRAME			
NO.	MATERIAL	LENGTH, mm	Qty.
1	2" x 2" x 3/16" angle bar	1,800.00	2
2	2" x 2" x 3/16" angle bar	500.00	2
3	1 1/4" x 1 1/4" x 2 mm square tube	493.65	2
4	1 1/4" x 1 1/4" x 2 mm square tube	968.25	6
5	1 1/4" x 1 1/4" x 2 mm square tube	1,800.00	2
6	1 1/4" x 1 1/4" x 2 mm square tube	500.00	2
7	1 1/4" x 1 1/4" x 2 mm square tube	436.50	2
8	1 1/4" x 1 1/4" x 2 mm square tube	1,473.00	1
9	1 1/4" x 1 1/4" x 2 mm square tube	967.04	2
10	1" x 1" x 1.5 mm square tube	436.5	2
11	1" x 1" x 1.5 mm square tube	392.04	2
12	1" x 1" x 1.5 mm square tube	1,473.00	1
13	1" x 1" x 1.5 mm square tube	43.25	2
14	1" x 1" x 1.5 mm square tube	225.00	2
15	Gauge #18 GI sheet, 2" x 2" @ 90 degrees bend	431.70	6
TOTAL			36

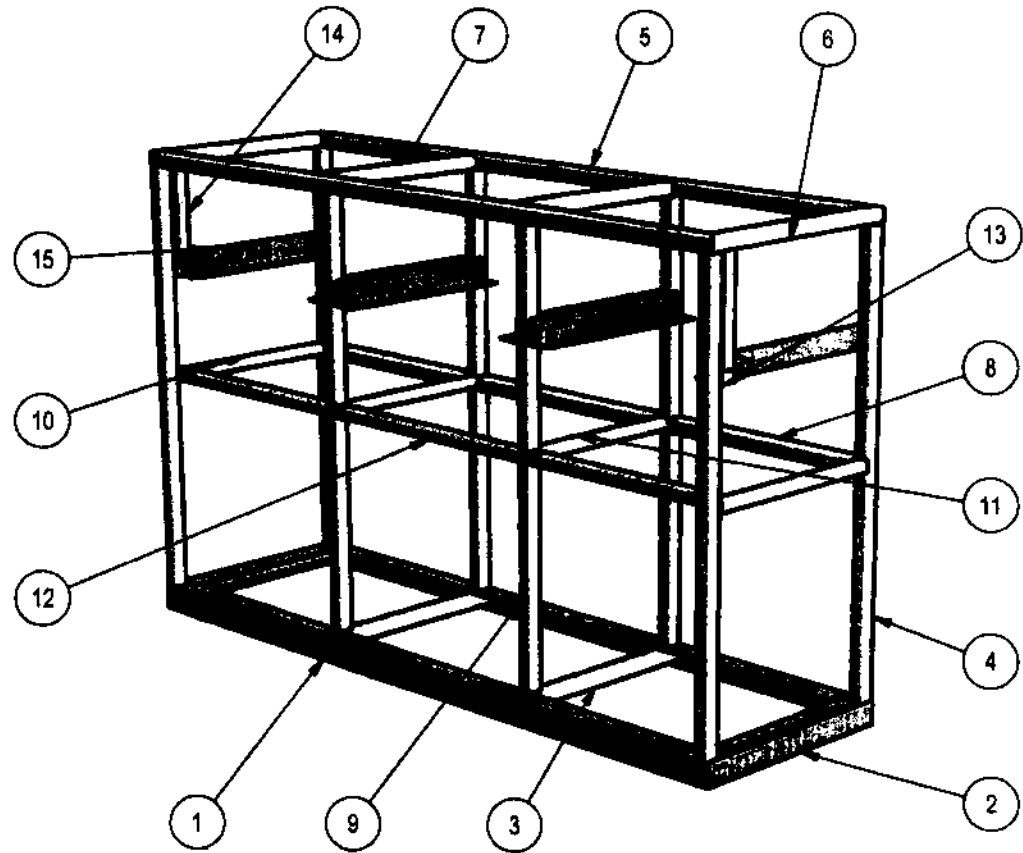

**MTL BOX NO. 3 FRAME  
(BREAD AND PASTRY)**  
(The door is not shown in the drawing)



TECHNICAL  
EDUCATION AND  
SKILLS  
DEVELOPMENT  
AUTHORITY

PROJECT TITLE:  
**MOBILE TRAINING  
LABORATORY**

DRAWN BY: JPA Scale: 1:15 Sheet No. 1

Handwritten notes and signatures in the bottom left corner, including '1/11' and 'JPA'.

PRODUCED BY AN AUTODESK EDUCATIONAL PRODUCT

PRODUCED BY AN AUTODESK EDUCATIONAL PRODUCT

**MTL BOX NO. 3**

- ◆ All materials must be painted with anti-corrosive primer
- ◆ □ tube and ∟ bar are coated with light gray epoxy finish paint

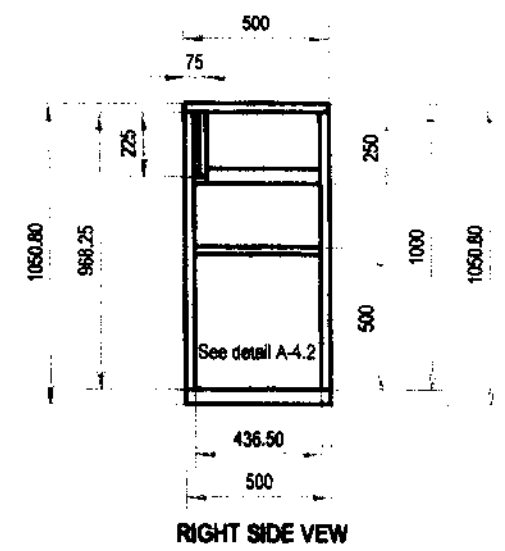
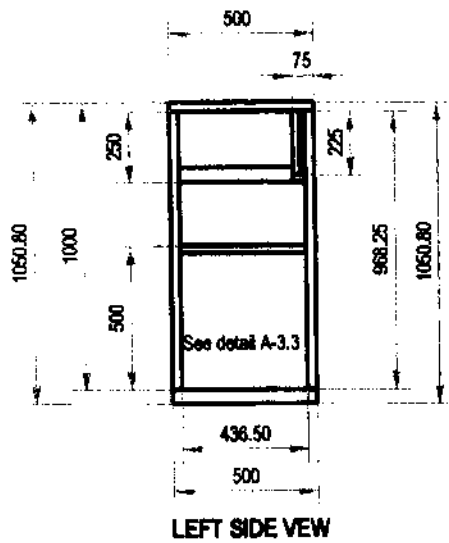
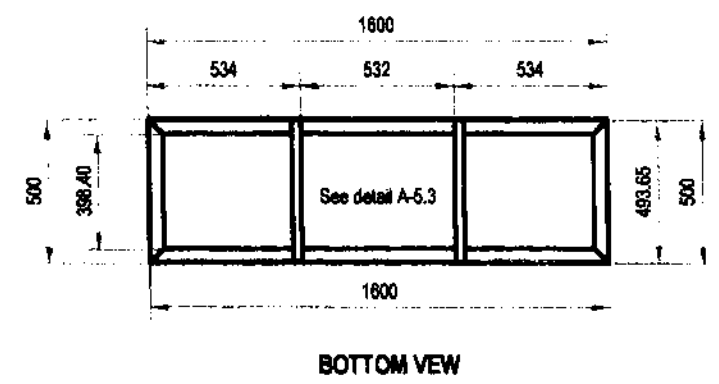
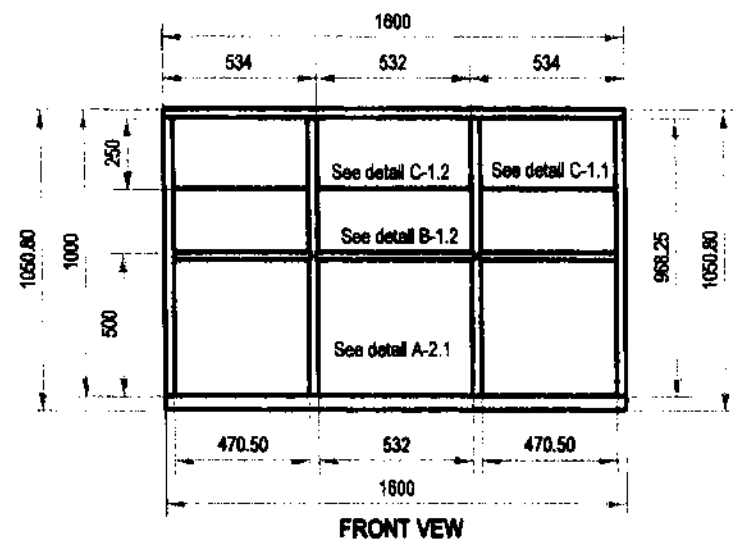
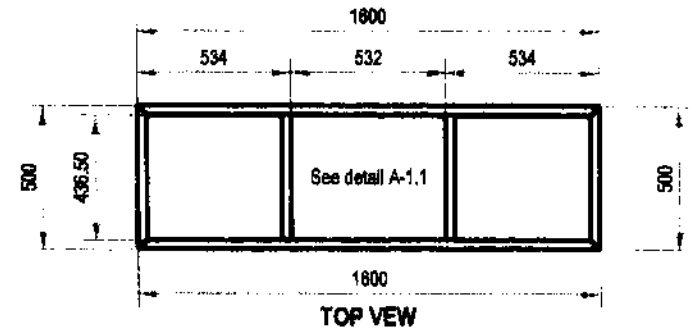

**MTL BOX NO. 3 FRAME  
(BREAD AND PASTRY)**  
(The door is not shown in the drawing)

	<b>TECHNICAL EDUCATION AND SKILLS DEVELOPMENT AUTHORITY</b>	<b>PROJECT TITLE: MOBILE TRAINING LABORATORY</b>

DETAIL A-1.1:

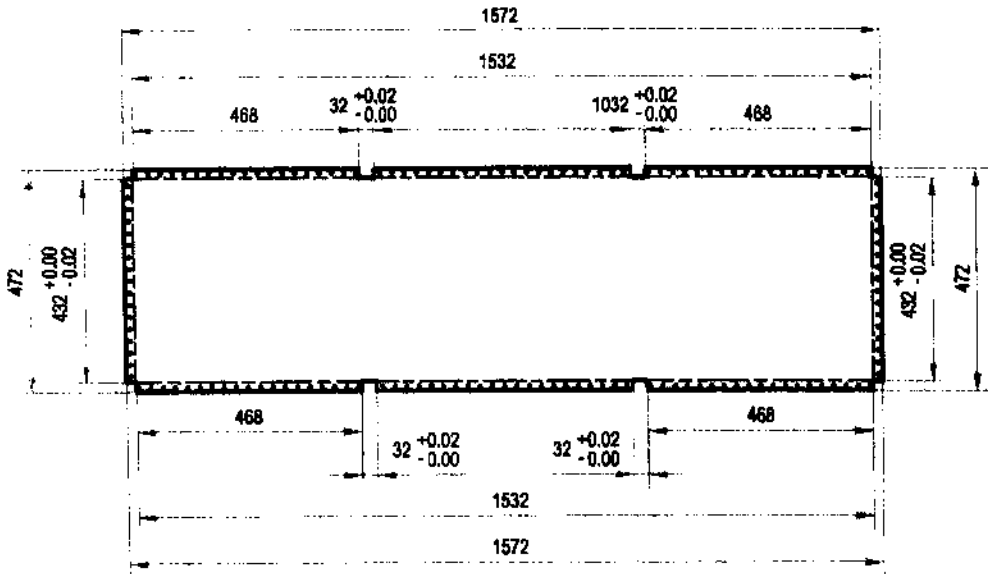

QUANTITY: 5

DETAIL A-1.3:

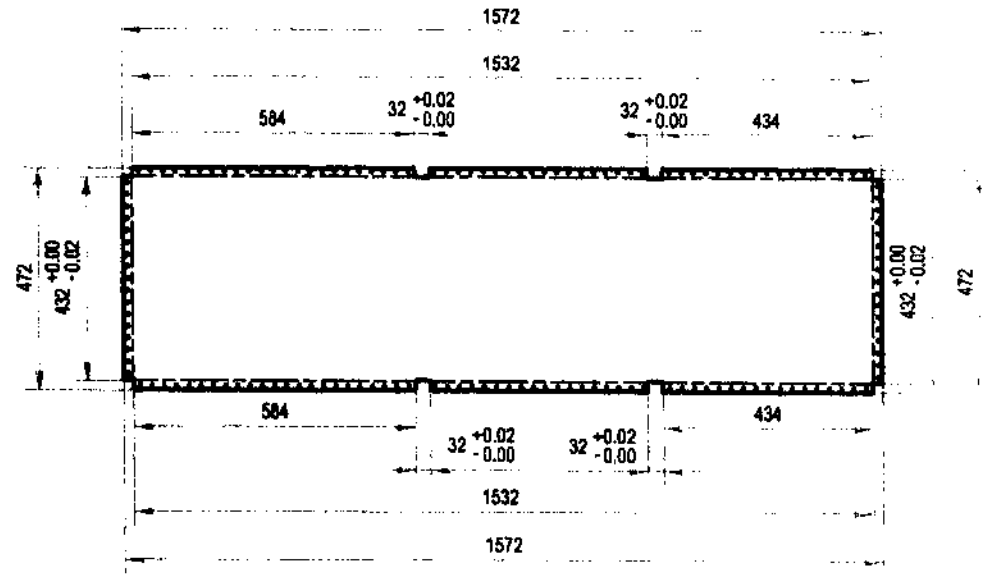

QUANTITY: 1

DETAIL A-1.2:

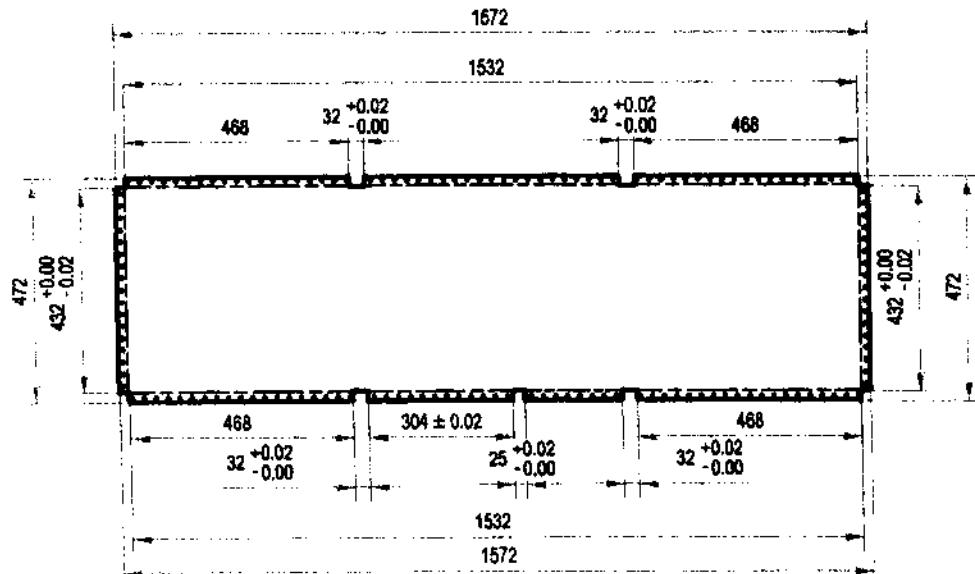

QUANTITY: 2

DETAIL A-1.4:

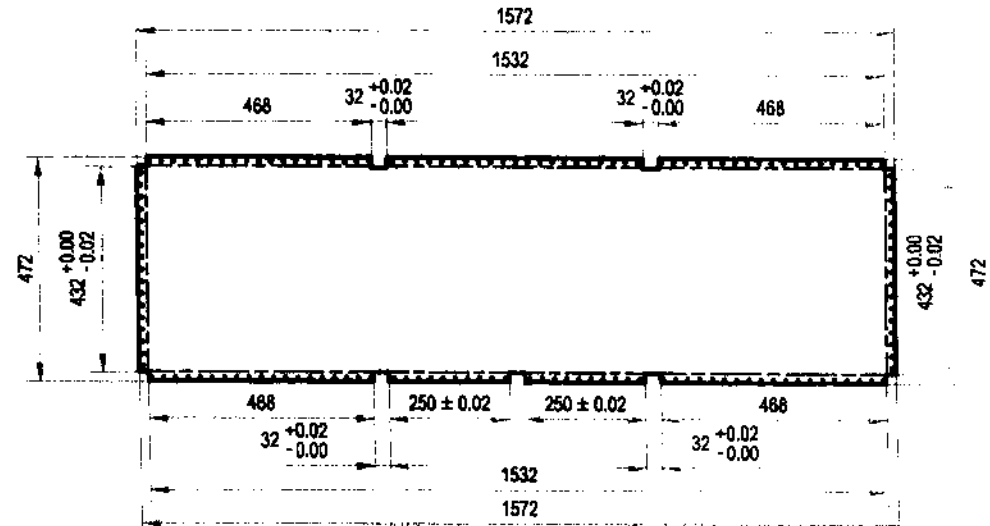

QUANTITY: 2

FLAT PATTERN: GALVANIZED SHEET GAUGE #18, PAINTED

Use 3/16" blind rivet spaced @ 1" O.C.



TECHNICAL  
EDUCATION AND  
SKILLS  
DEVELOPMENT  
AUTHORITY

PROJECT TITLE:  
MOBILE TRAINING  
LABORATORY

DRAWN BY: JPA Scale: 1:16 Sheet No.:

PRODUCED BY AN AUTODESK EDUCATIONAL PRODUCT

PRODUCED BY AN AUTODESK EDUCATIONAL PRODUCT

DETAIL A-2.1:

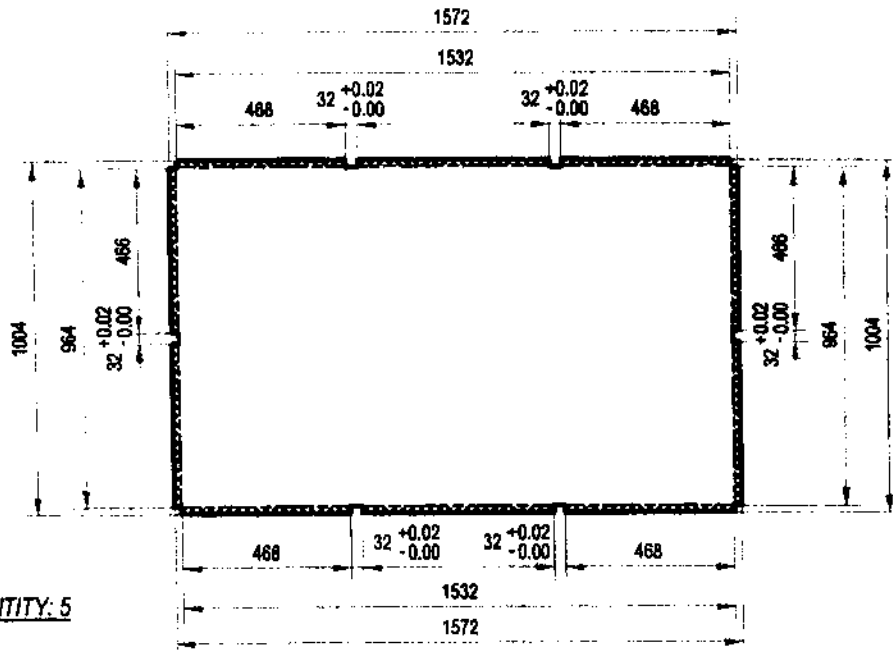

QUANTITY: 5

DETAIL A-2.3:

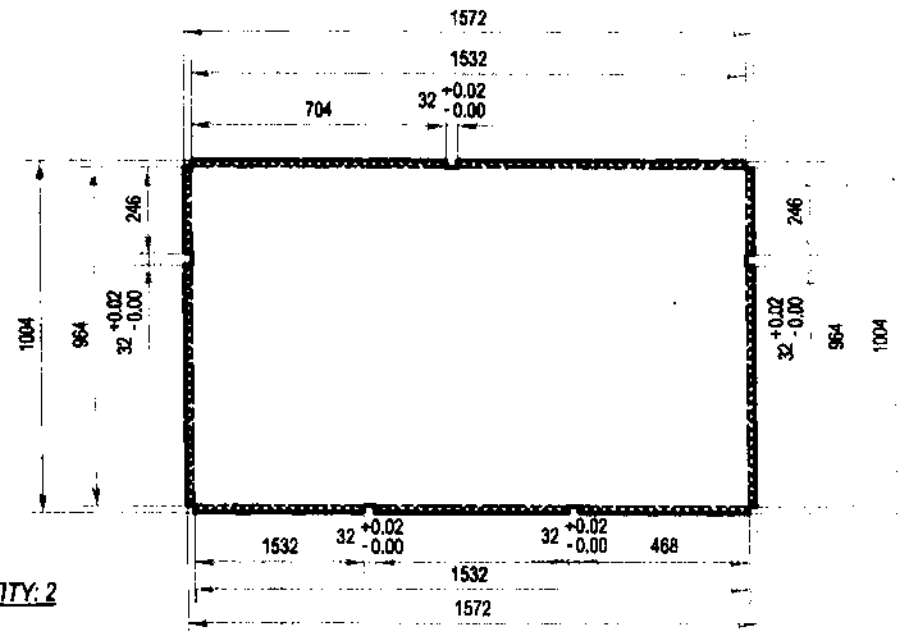

QUANTITY: 2

DETAIL A-2.2:

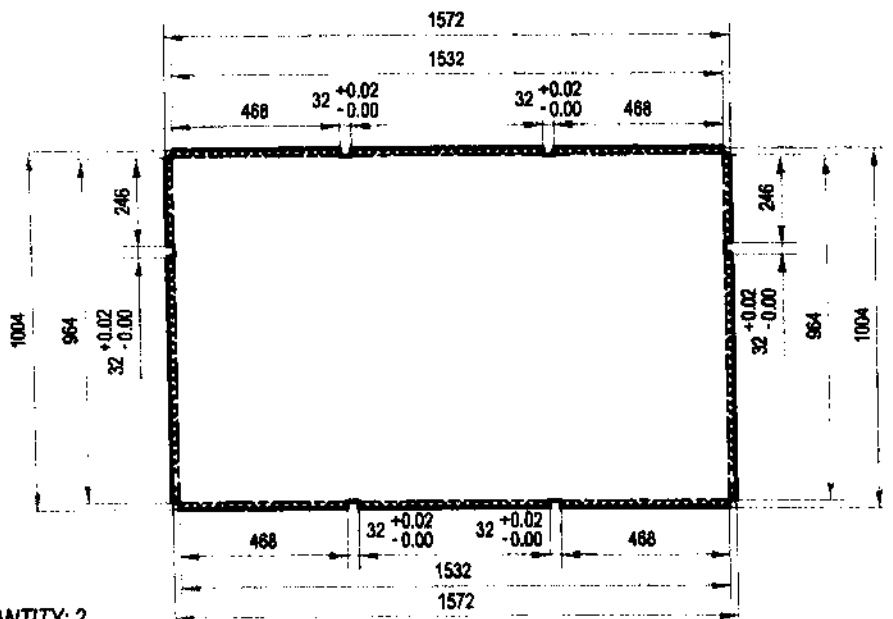

QUANTITY: 2

DETAIL A-2.4:

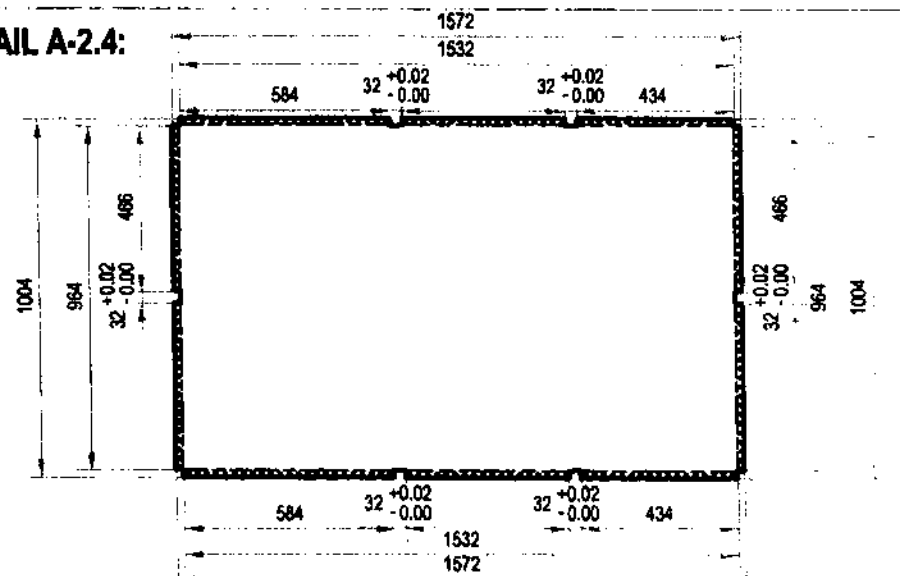

QUANTITY: 1

FLAT PATTERN: GALVANIZED SHEET GAUGE #18, PAINTED

Use 3/16" blind rivet spaced @ 1" O.C.



TECHNICAL EDUCATION AND SKILLS DEVELOPMENT AUTHORITY

PROJECT TITLE: MOBILE TRAINING LABORATORY

DRAWN BY: JPA SCALE: 1:20 SHEET NO: 17

PRODUCED BY AN AUTODESK EDUCATIONAL PRODUCT

PRODUCED BY AN AUTODESK EDUCATIONAL PRODUCT



DETAIL A-3.1:

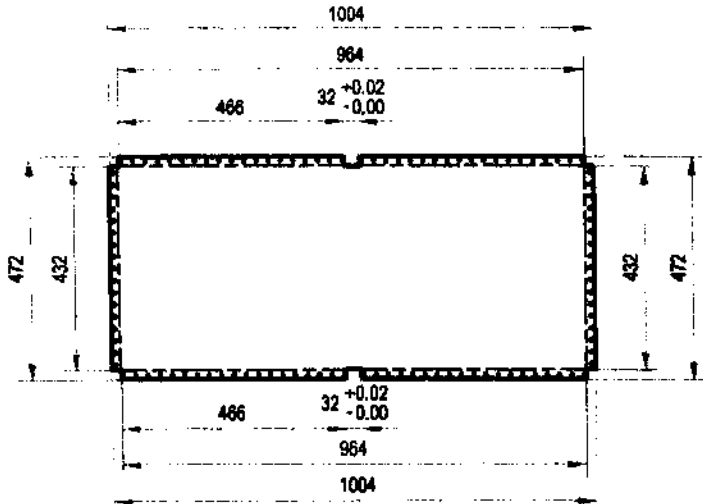

QUANTITY: 5

DETAIL A-3.3:

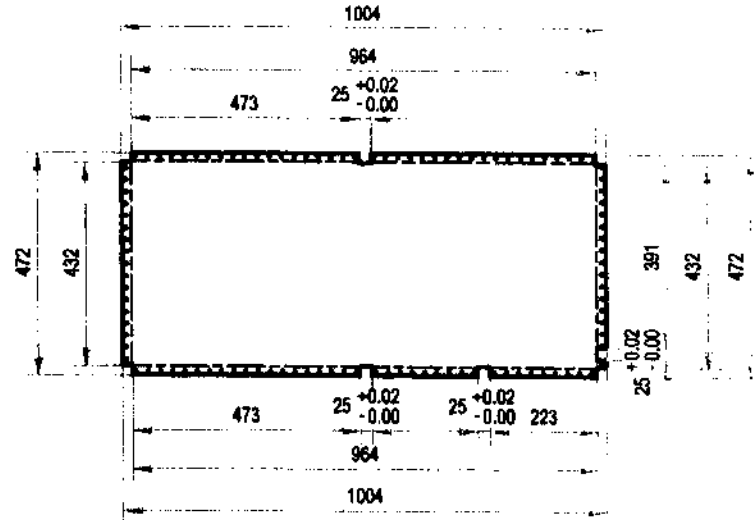

QUANTITY: 1

DETAIL A-3.2:

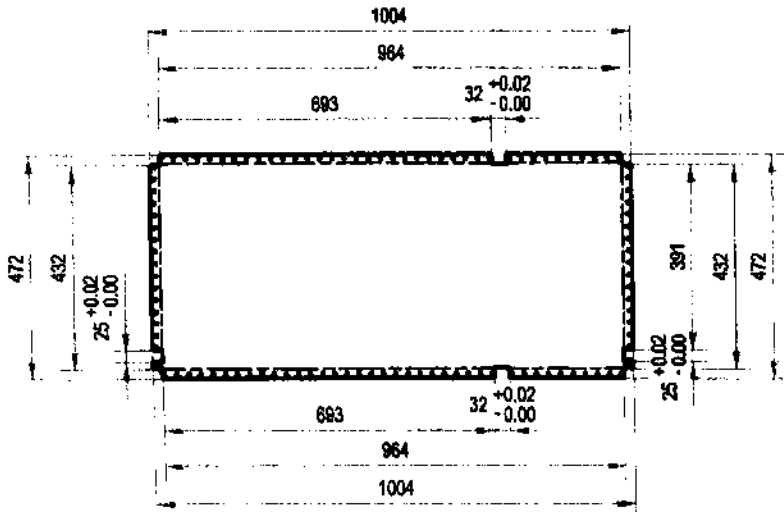

QUANTITY: 4

DETAIL A-3.4:

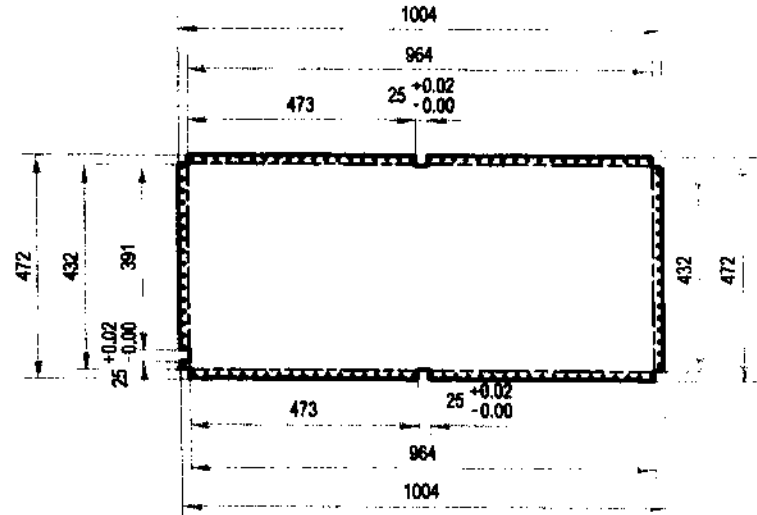

QUANTITY: 2

FLAT PATTERN: GALVANIZED SHEET GAUGE #18, PAINTED

Use 3/16" blind rivet spaced @ 1" O.C.



TECHNICAL EDUCATION AND SKILLS DEVELOPMENT AUTHORITY

PROJECT TITLE: MOBILE TRAINING LABORATORY

DRAWN BY: JPA SCHE: 1-15 Sheet No.

PRODUCED BY AN AUTODESK EDUCATIONAL PRODUCT

PRODUCED BY AN AUTODESK EDUCATIONAL PRODUCT

DETAIL A-4.1:

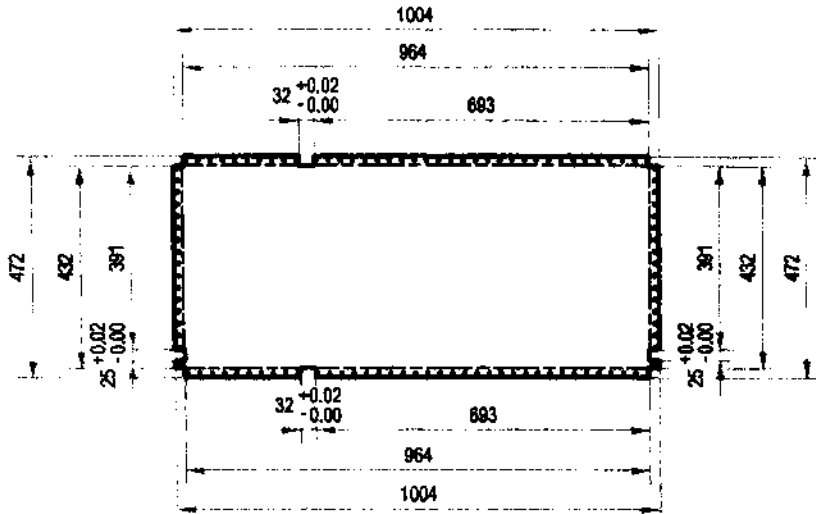

QUANTITY: 4

DETAIL A-4.2:

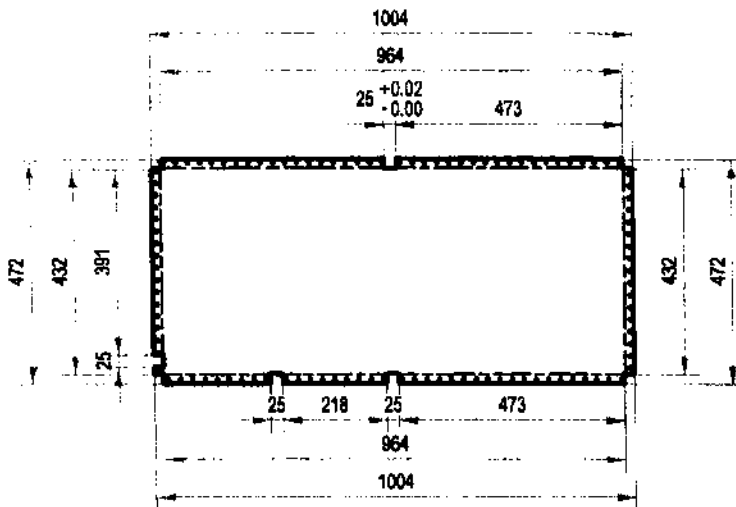

QUANTITY: 2

DETAIL A-4.3:

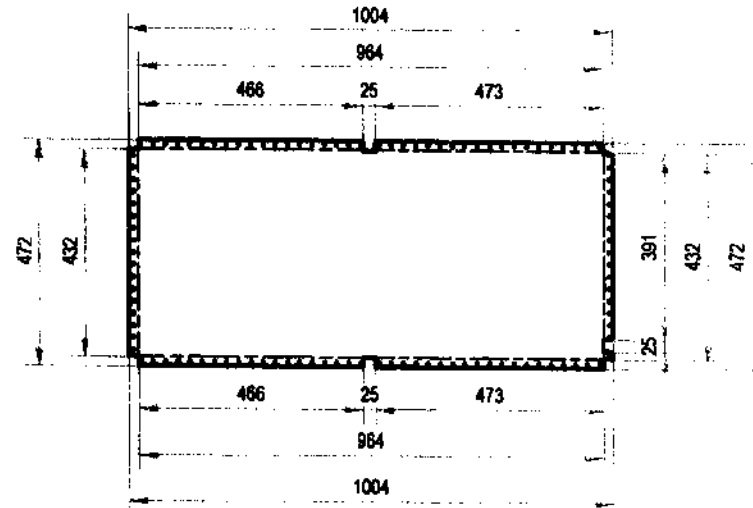

QUANTITY: 2

FLAT PATTERN: GALVANIZED SHEET GAUGE #18, PAINTED

PRODUCED BY AN AUTODESK EDUCATIONAL PRODUCT

PRODUCED BY AN AUTODESK EDUCATIONAL PRODUCT

*Handwritten initials and date: JAS 1/18*

Use 3/16" blind rivet spaced @ 1" O.C.

	TECHNICAL EDUCATION AND SKILLS DEVELOPMENT AUTHORITY	PROJECT TITLE: <b>MOBILE TRAINING LABORATORY</b>
	DRAWN BY: JJA	SCALE: 1:15

DETAIL A-5.1:

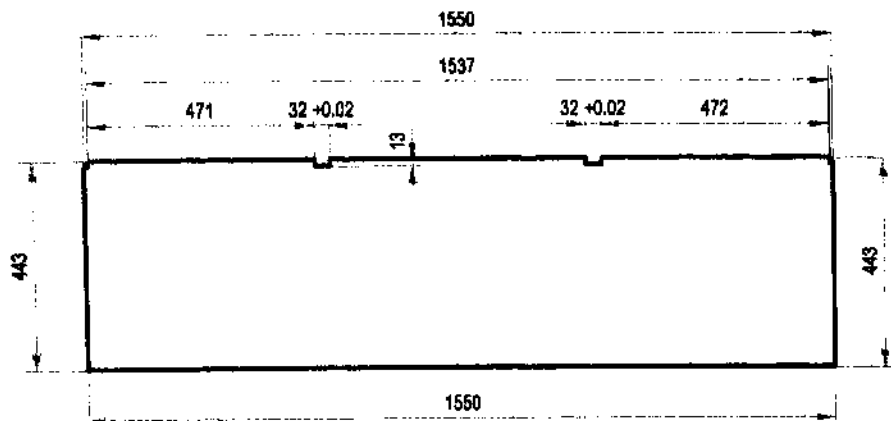

QUANTITY: 1

DETAIL A-5.3:

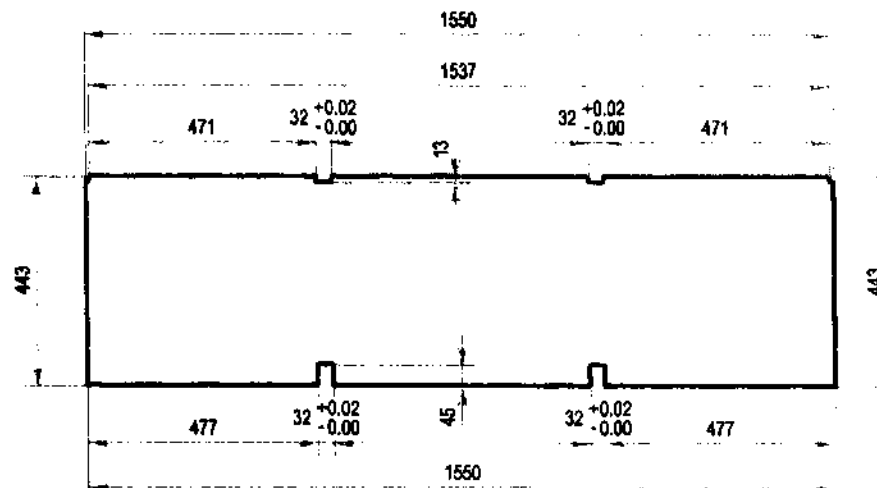

QUANTITY: 2

DETAIL A-5.2:

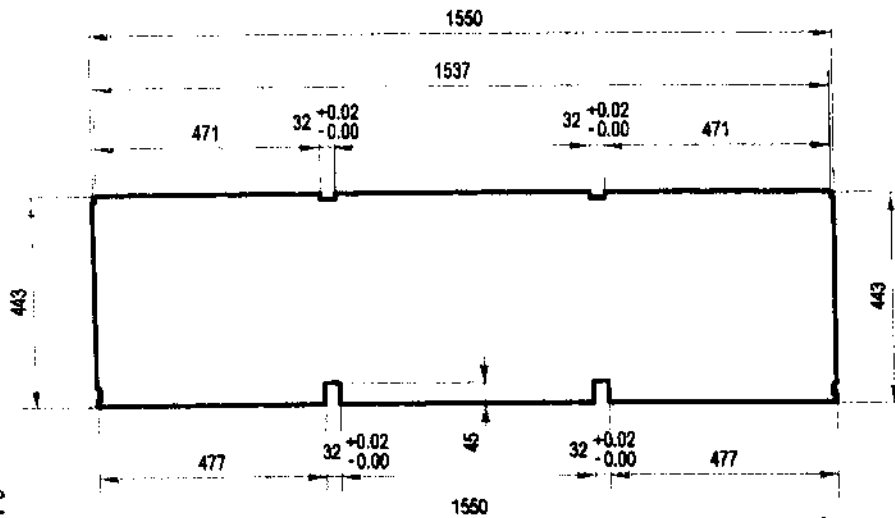

QUANTITY: 6

DETAIL A-5.4:

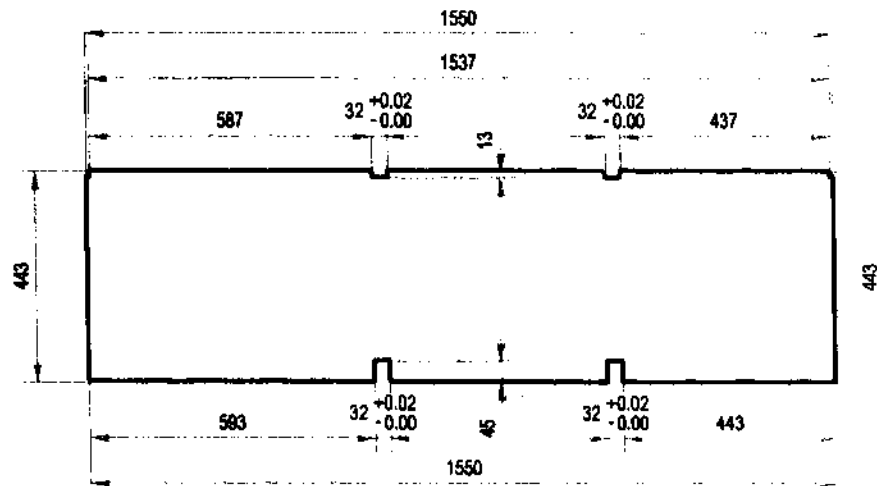

QUANTITY: 1

GALVANIZED SHEET GAUGE #18, PAINTED



TECHNICAL  
EDUCATION AND  
SKILLS  
DEVELOPMENT  
AUTHORITY

PROJECT TITLE:  
**MOBILE TRAINING  
LABORATORY**

DRAWN BY: JPA Scale: 1:15 Sheet No.:

PRODUCED BY AN AUTODESK EDUCATIONAL PRODUCT

PRODUCED BY AN AUTODESK EDUCATIONAL PRODUCT

DETAIL B-1.1:

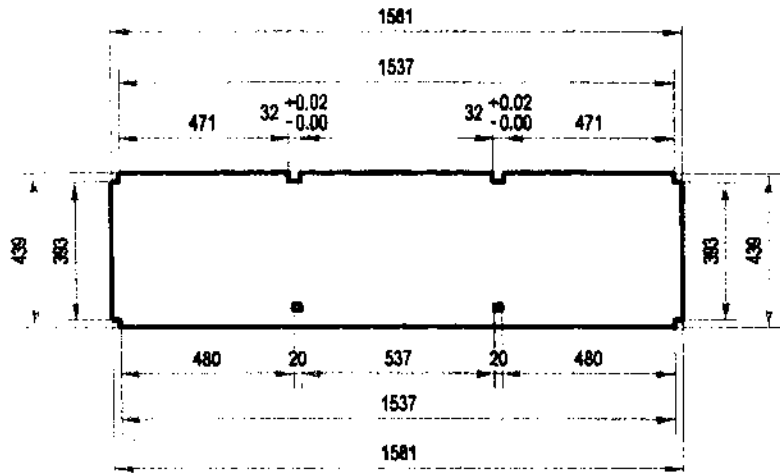

QUANTITY: 2

DETAIL B-1.3:

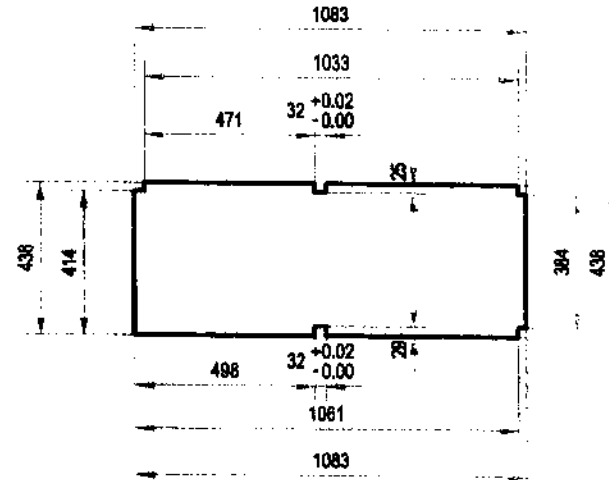

QUANTITY: 1

DETAIL B-1.2:

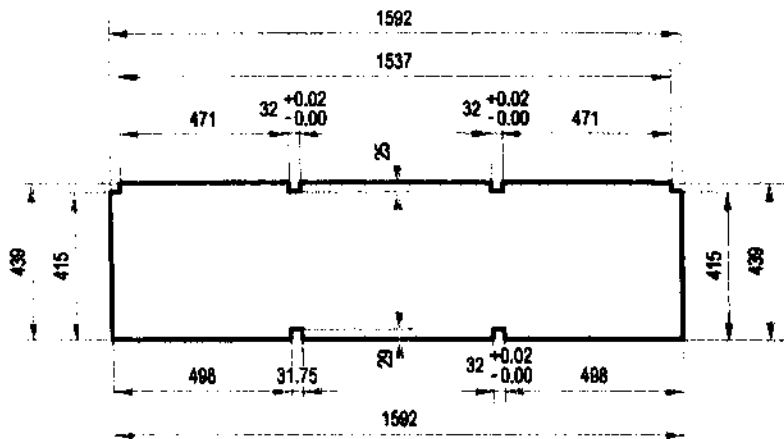

DETAIL B-1.4:

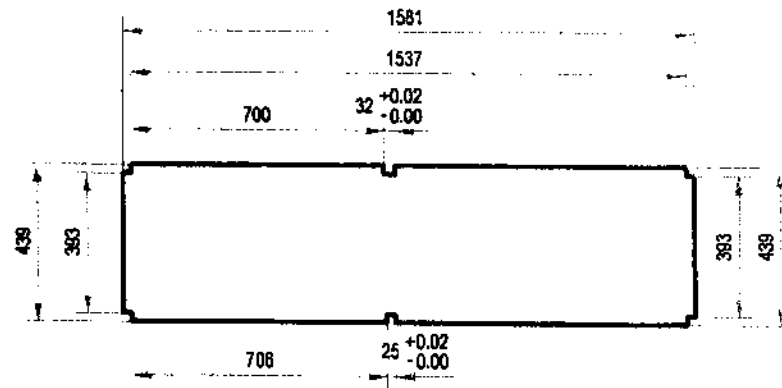

QUANTITY: 2

GALVANIZED SHEET GAUGE #18, PAINTED

PRODUCED BY AN AUTODESK EDUCATIONAL PRODUCT

PRODUCED BY AN AUTODESK EDUCATIONAL PRODUCT

*Handwritten initials and date:*  
 1/10/11  
 JMB  
 JMB

QUANTITY: 1

	TECHNICAL EDUCATION AND SKILLS DEVELOPMENT AUTHORITY	PROJECT TITLE: <b>MOBILE TRAINING                  LABORATORY</b>
	DRAWN BY: JPA	Scale: 1:20

**DETAIL C-1.1:**

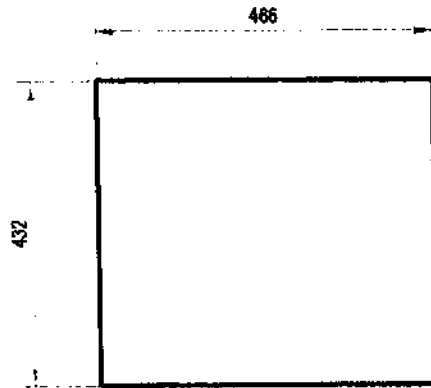

QUANTITY: 15

**DETAIL C-1.3:**

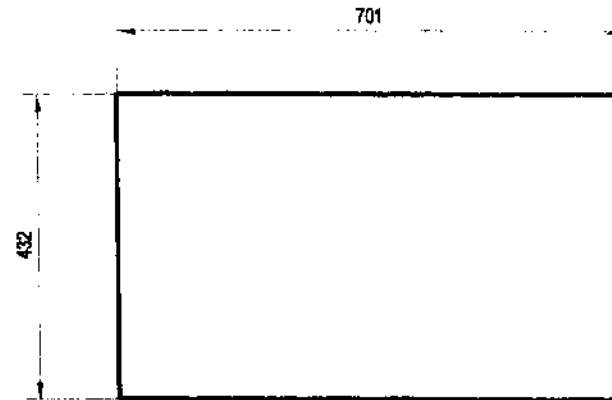

QUANTITY: 2

**DETAIL C-1.2:**

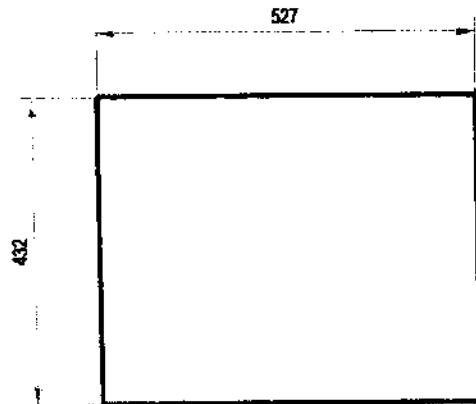

QUANTITY: 9

**DETAIL D-1.1:**

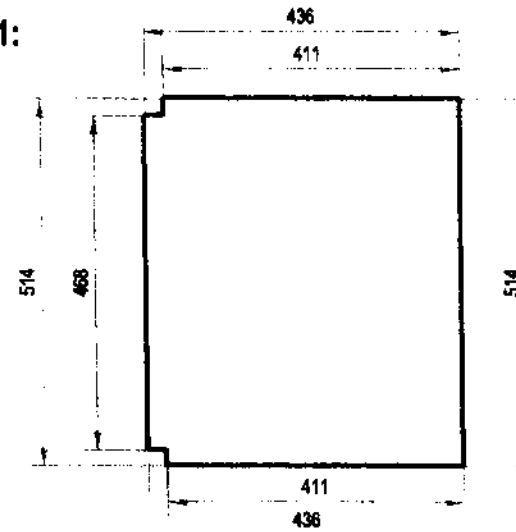

QUANTITY: 1

GALVANIZED SHEET GAUGE #18, PAINTED



TECHNICAL  
EDUCATION AND  
SKILLS  
DEVELOPMENT  
AUTHORITY

PROJECT TITLE:  
**MOBILE TRAINING  
LABORATORY**

Drawn by: J.A. Scale: 1:10 Sheet No.:

PRODUCED BY AN AUTODESK EDUCATIONAL PRODUCT

PRODUCED BY AN AUTODESK EDUCATIONAL PRODUCT

*Handwritten notes:*  
Laminated  
J.A.

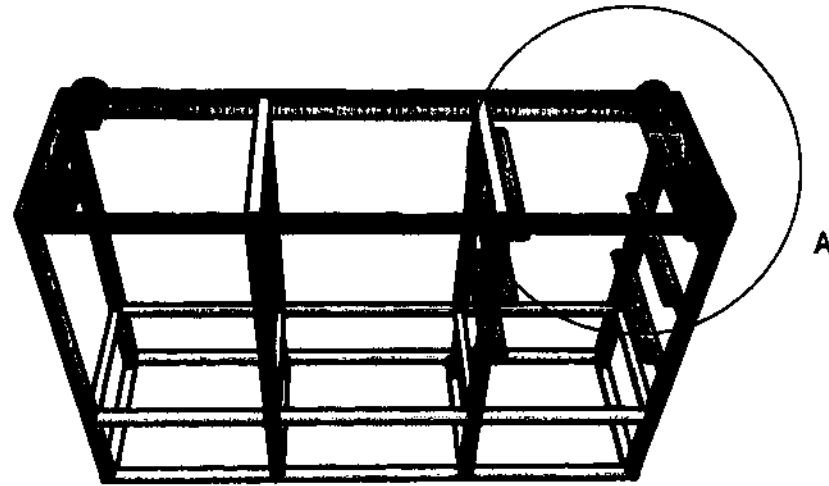

A ( 1 : 10 )

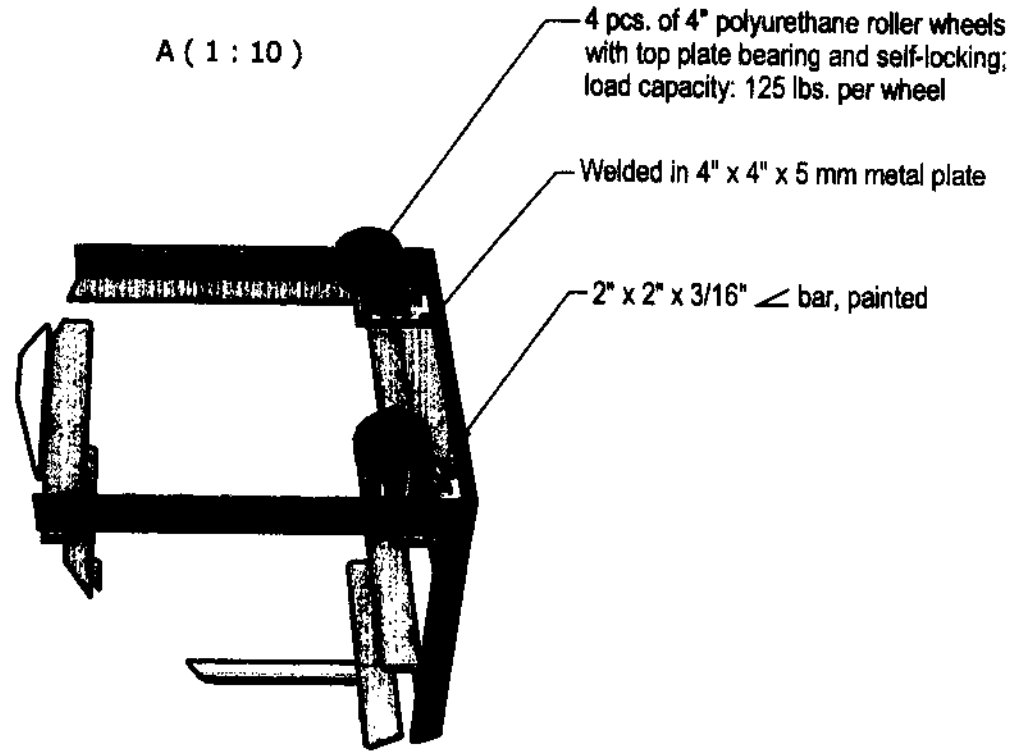

*Handwritten signature*



TECHNICAL  
EDUCATION AND  
SKILLS  
DEVELOPMENT  
AUTHORITY

PROJECT TITLE:  
**MOBILE TRAINING  
LABORATORY**

DRAWN BY: JPA Scale: 1:20

Sheet No.:

DETAIL F: RUBBER DOOR SEAL

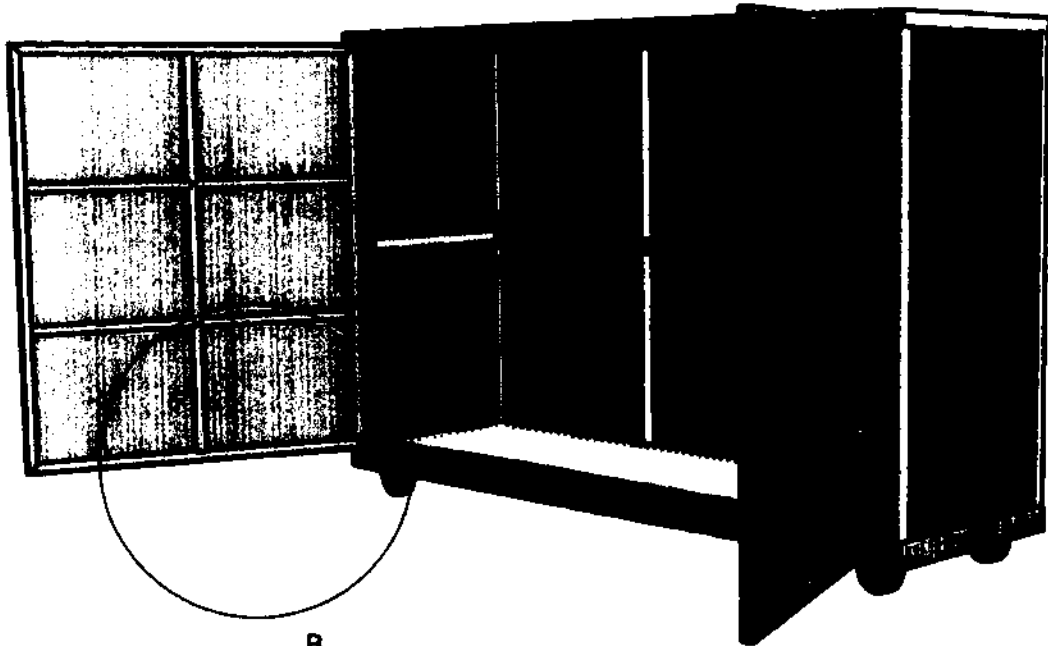

B

B ( 1:10 )

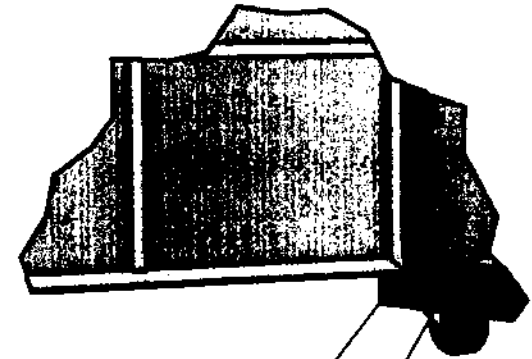

34" Door rubber seal, black

1" x 3/16" flat bar

PRODUCED BY AN AUTODESK EDUCATIONAL PRODUCT

PRODUCED BY AN AUTODESK EDUCATIONAL PRODUCT

*Handwritten initials and date: JPA 2/20*

	TECHNICAL EDUCATION AND SKILLS DEVELOPMENT AUTHORITY	PROJECT TITLE: <b>MOBILE TRAINING LABORATORY</b>
	DRAWN BY: JPA	Scale: 1:25

MTL BOX COVER FRAME, SIDEWAY SWING

NO.	MATERIAL	LENGTH, mm	Qty.
1	Gauge #18 G.I. sheet	1,009 x 835	2
2	1" x 1" x 1.5 mm square tube	968.25	4
3	1" x 1" x 1.5 mm square tube	928.25	2
4	1" x 1" x 1.5 mm square tube	793.65	4
5	1" x 1" x 1.5 mm square tube	369.825	8
6	2" x 2mm piano hinge	968	2
TOTAL			22

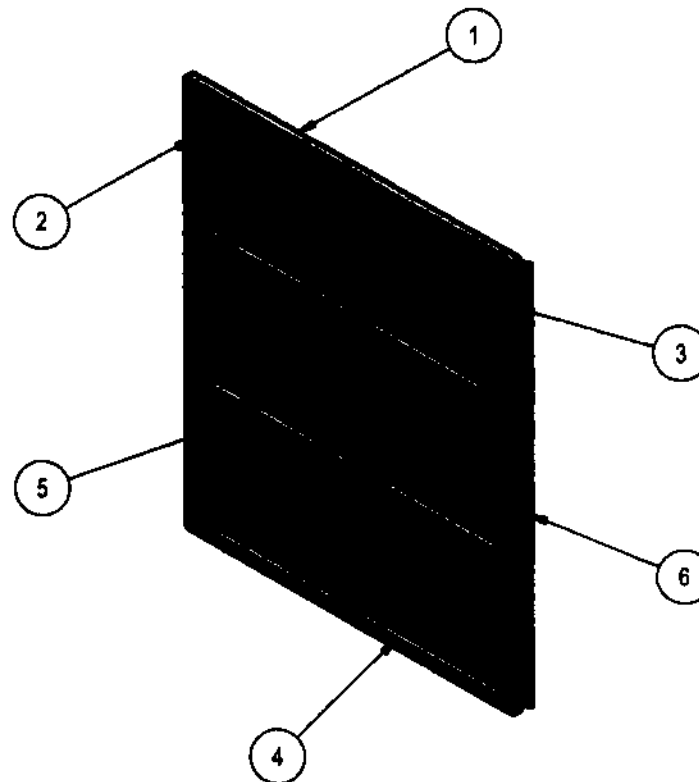

MTL DOOR FRAME

	TECHNICAL EDUCATION AND SKILLS DEVELOPMENT AUTHORITY	PROJECT TITLE:
		<b>MOBILE TRAINING LABORATORY</b>

*Handwritten notes:*  
 2/10/08  
 [Signature]



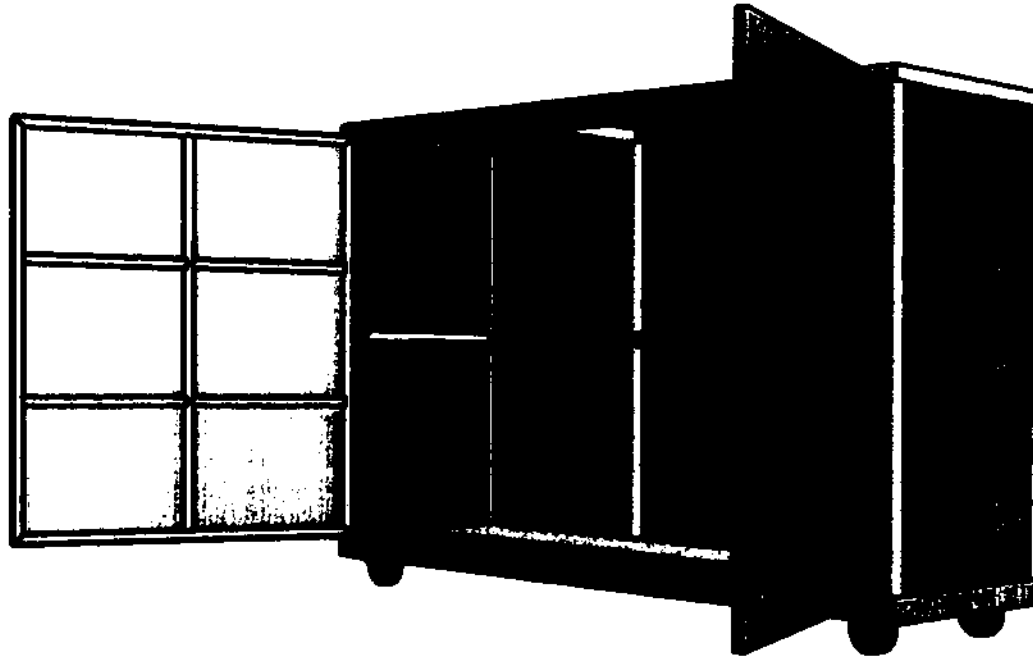

Include 2-sides metal handle  
and lock with padlock for the  
door (not shown in the drawing)

*Handwritten signature and initials*

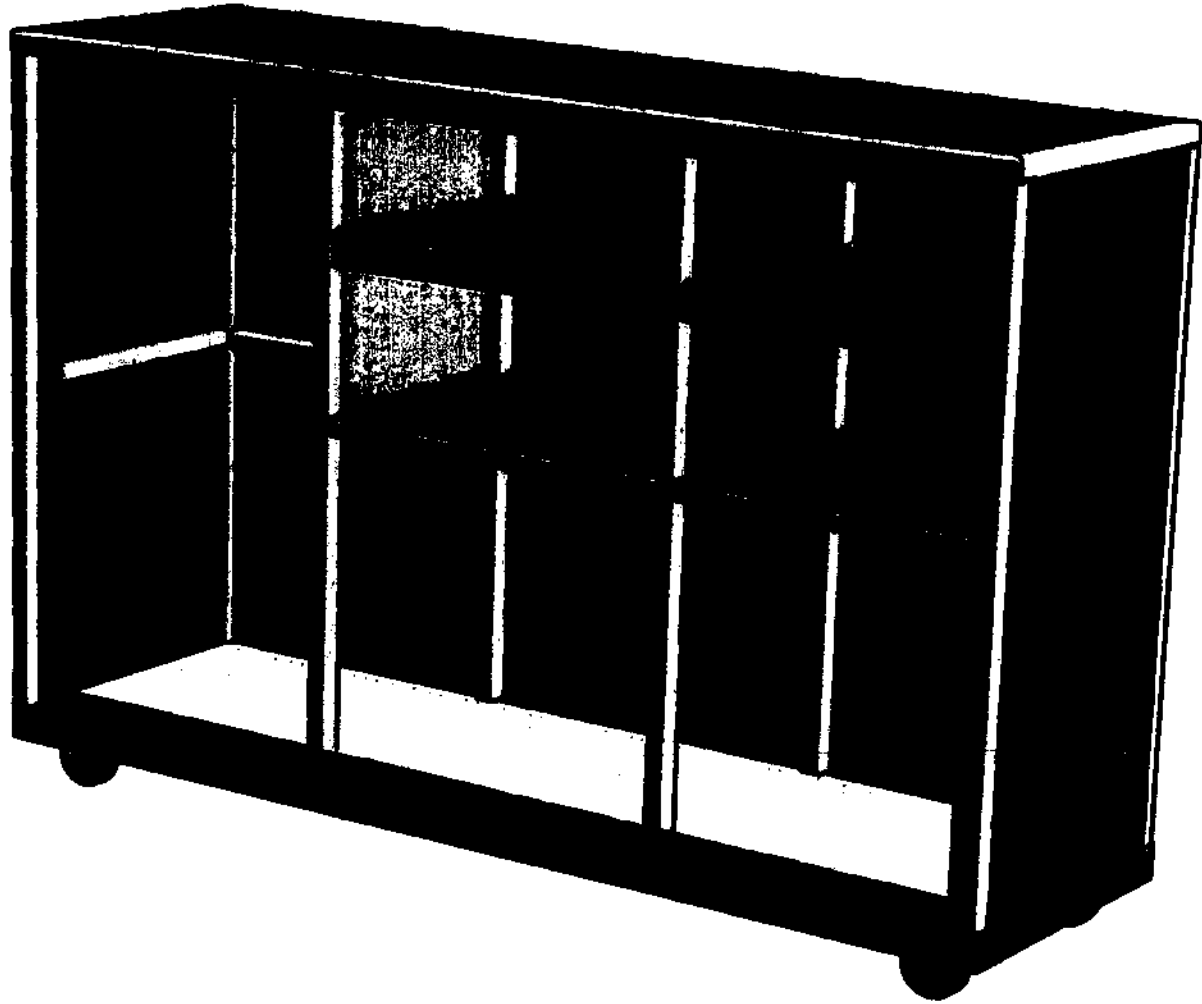

**MTL BOX NO. 4**  
**(BREAD AND PASTRY)**  
**QUANTITY:**  
(The door is not shown in the drawing)

PRODUCED BY AN AUTODESK EDUCATIONAL PRODUCT

PRODUCED BY AN AUTODESK EDUCATIONAL PRODUCT

*Handwritten initials and a signature.*

	TECHNICAL EDUCATION AND SKILLS DEVELOPMENT AUTHORITY	PROJECT TITLE: <b>MOBILE TRAINING LABORATORY</b>	
		DRAWN BY: JVA	Scale: 1:10 Sheet No.: 1 /

MTL BOX 4 FRAME			
NO.	MATERIAL	LENGTH, mm	Qty.
1	2" x 2" x 3/16" angle bar	1,600.00	2
2	2" x 2" x 3/16" angle bar	500.00	2
3	1 1/4" x 1 1/4" x 2 mm square tube	493.65	2
4	1 1/4" x 1 1/4" x 2 mm square tube	968.25	6
5	1 1/4" x 1 1/4" x 2 mm square tube	1,600.00	2
6	1 1/4" x 1 1/4" x 2 mm square tube	500.00	2
7	1 1/4" x 1 1/4" x 2 mm square tube	436.50	2
8	1 1/4" x 1 1/4" x 2 mm square tube	1,473.00	1
9	1 1/4" x 1 1/4" x 2 mm square tube	971.80	2
10	1" x 1" x 1.5 mm square tube	436.50	2
11	1" x 1" x 1.5 mm square tube	385.29	2
12	1" x 1" x 1.5 mm square tube	1,002.50	1
13	1" x 1" x 1.5 mm square tube	43.25	1
14	1" x 1" x 1.5 mm square tube	225.00	1
15	Gauge #18 GI sheet, 2" x 2" @ 90 degrees bend	431.70	6
TOTAL			34

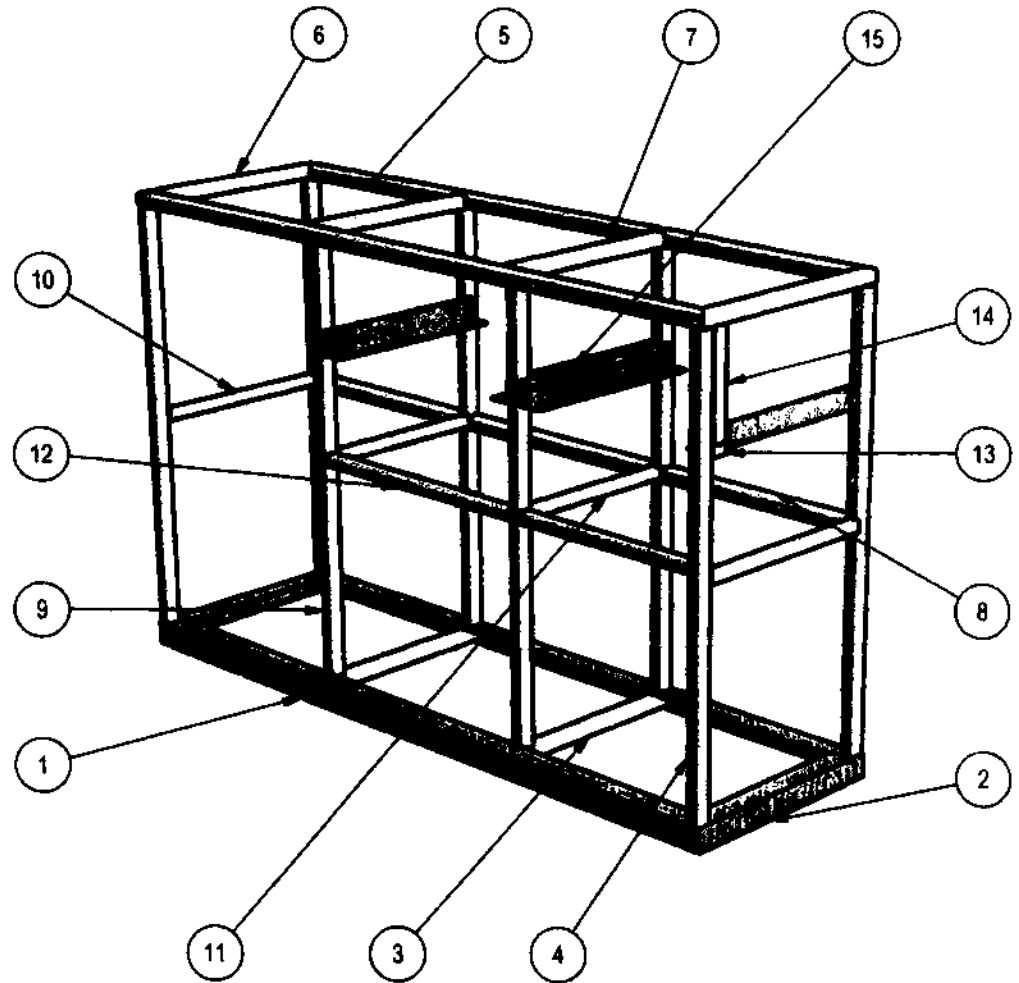

**MTL BOX NO. 4 FRAME  
(BREAD AND PASTRY)**  
(The door is not shown in the drawing)

	<b>TECHNICAL EDUCATION AND SKILLS DEVELOPMENT AUTHORITY</b>	PROJECT TITLE:
		<b>MOBILE TRAINING LABORATORY</b>

*Handwritten signature and initials.*

**MTL BOX NO. 4**

- ⊕ All materials must be painted with anti-corrosive primer
- ⊕ □ tube and ∟ bar are coated with light gray epoxy finish paint

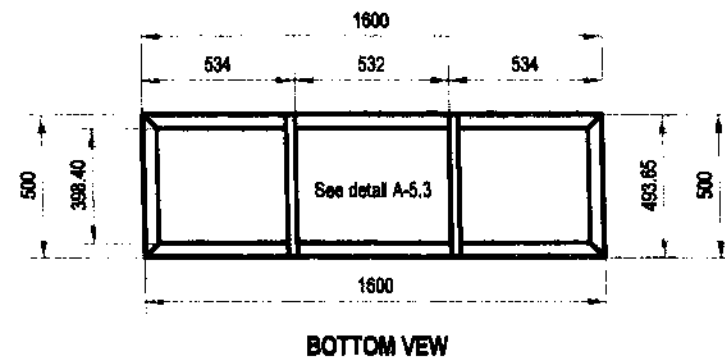
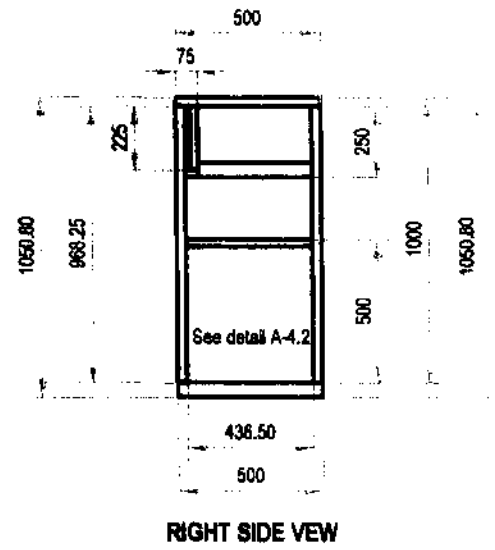
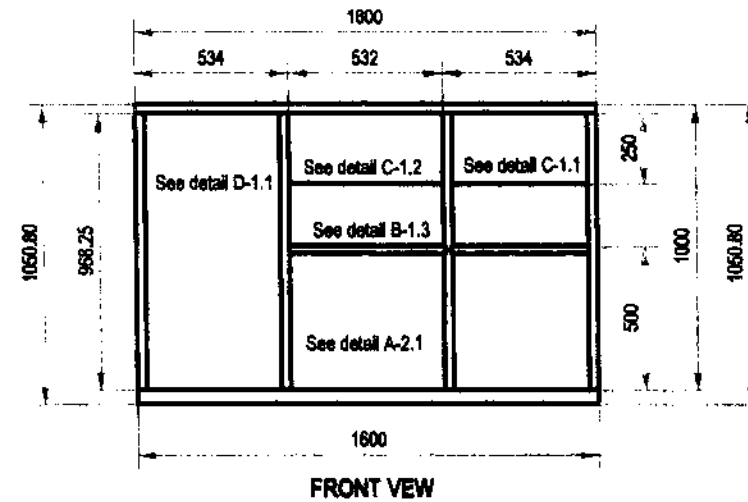
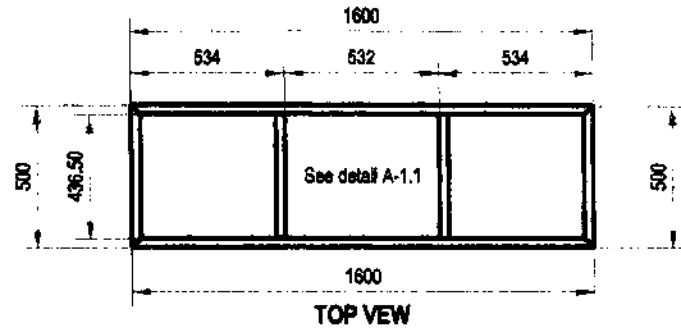
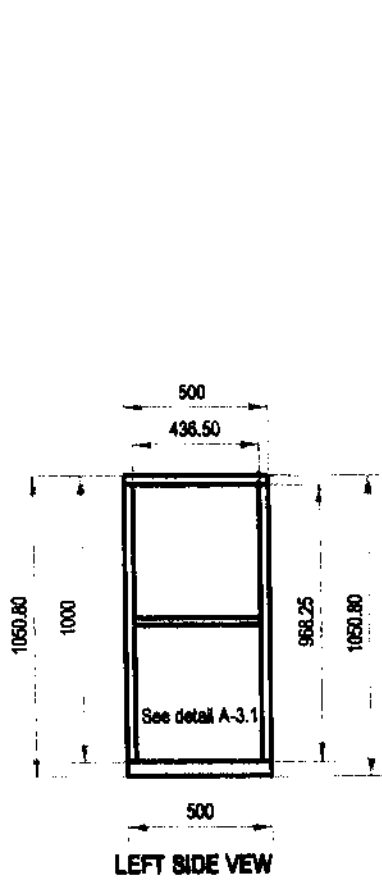

**MTL BOX NO. 4 FRAME  
(BREAD AND PASTRY)**  
(The door is not shown in the drawing)

	<b>TECHNICAL EDUCATION AND SKILLS DEVELOPMENT AUTHORITY</b>	PROJECT TITLE: <b>MOBILE TRAINING LABORATORY</b>
	<small>Sheet No.</small>	

DETAIL A-1.1:

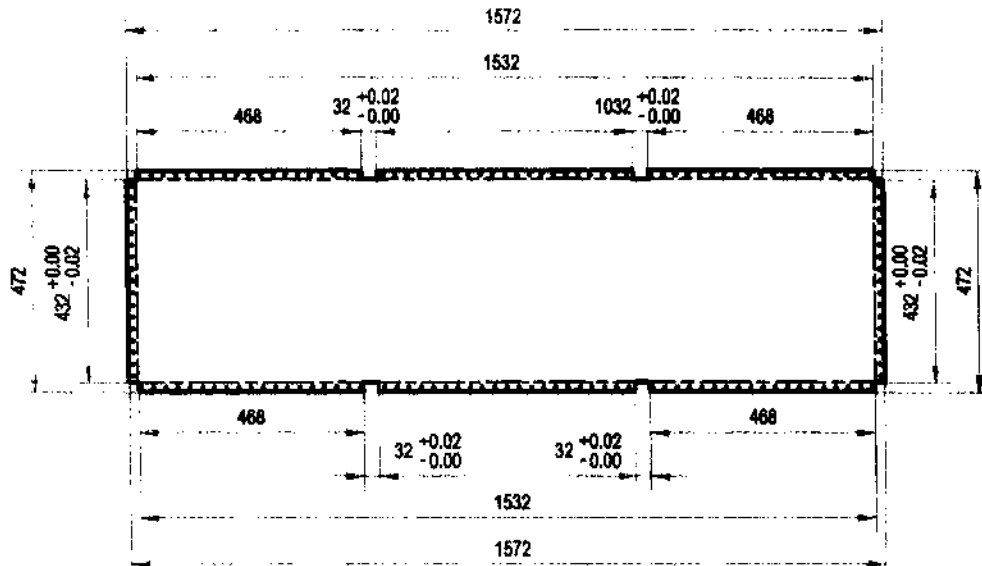

QUANTITY: 5

DETAIL A-1.2:

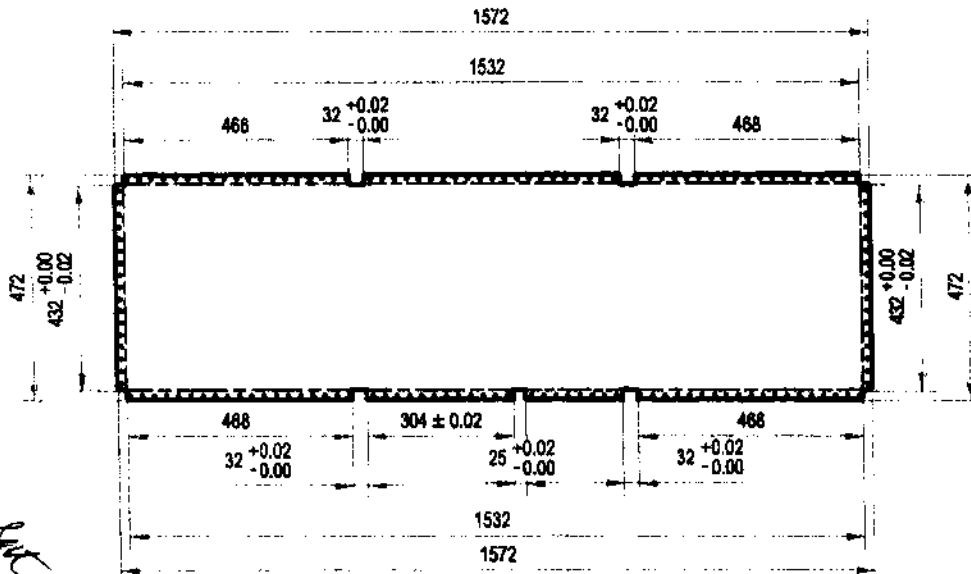

QUANTITY: 2

FLAT PATTERN: GALVANIZED SHEET GAUGE #18, PAINTED

DETAIL A-1.3:

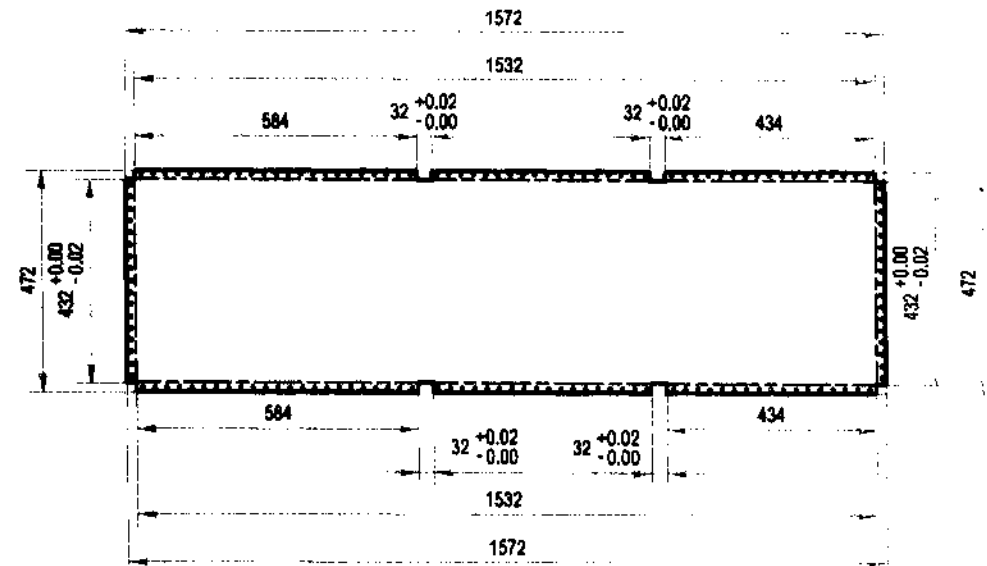

QUANTITY: 1

DETAIL A-1.4:

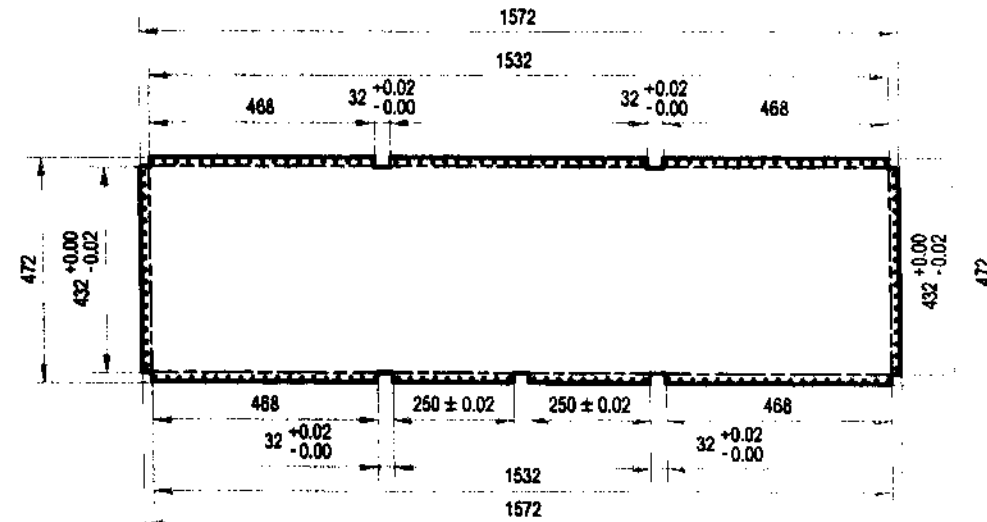

QUANTITY: 2

Use 3/16" blind rivet spaced @ 1' O.C.



TECHNICAL EDUCATION AND SKILLS DEVELOPMENT AUTHORITY

PROJECT TITLE: MOBILE TRAINING LABORATORY

DRAWN BY: [blank] Scale: 1:10 [blank] Sheet No.: [blank]

PRODUCED BY AN AUTODESK EDUCATIONAL PRODUCT

PRODUCED BY AN AUTODESK EDUCATIONAL PRODUCT

DETAIL A-2.1:

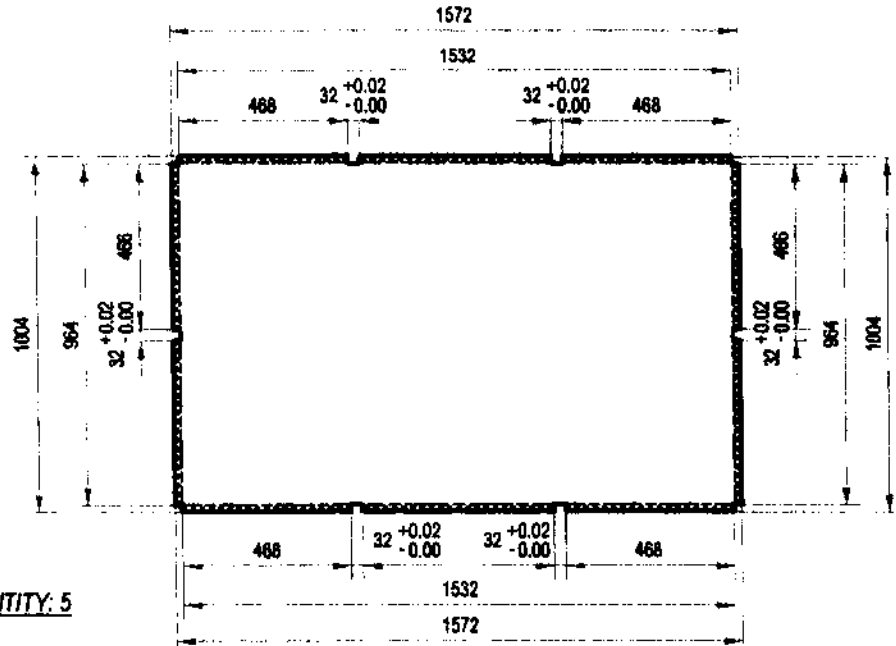

QUANTITY: 5

DETAIL A-2.3:

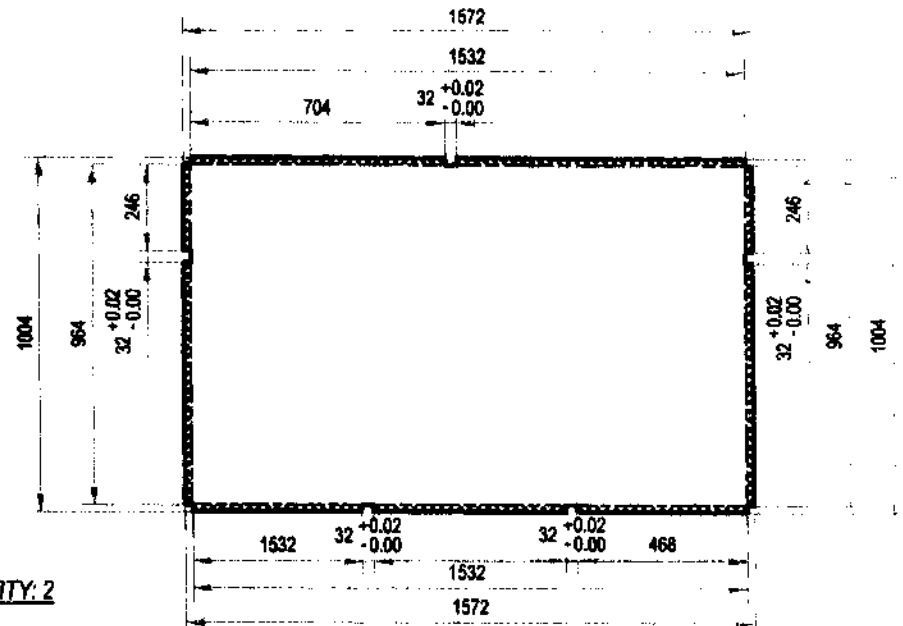

QUANTITY: 2

DETAIL A-2.2:

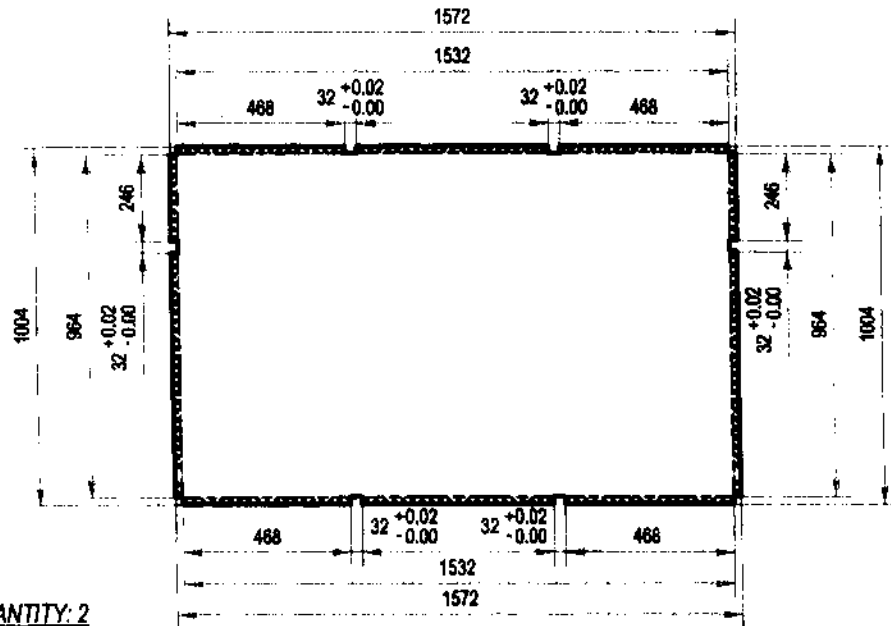

QUANTITY: 2

DETAIL A-2.4:

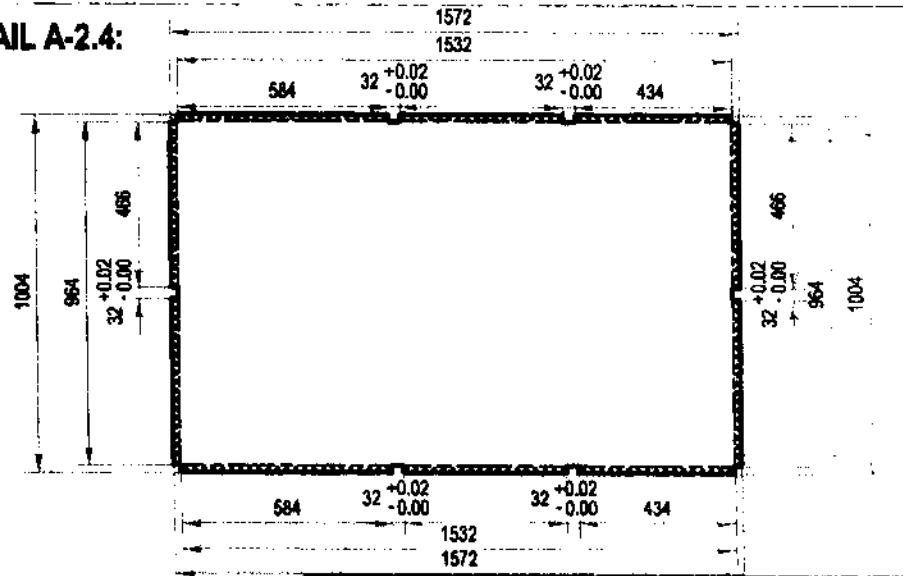

QUANTITY: 1

FLAT PATTERN: GALVANIZED SHEET GAUGE #18, PAINTED

Use 3/8" blind rivet spaced @ 1" O.C.



TECHNICAL EDUCATION AND SKILLS DEVELOPMENT AUTHORITY

PROJECT TITLE: MOBILE TRAINING LABORATORY

Drawn by: JVA Scale: 1:20 Sheet No: 1/

DETAIL A-3.1:

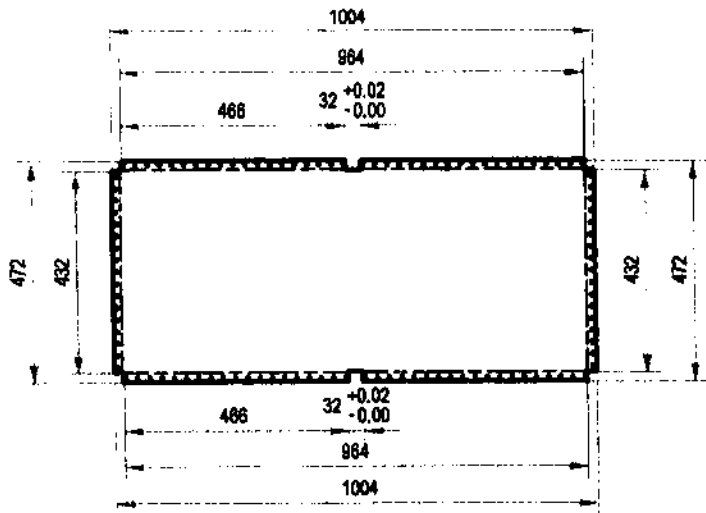

QUANTITY: 5

DETAIL A-3.3:

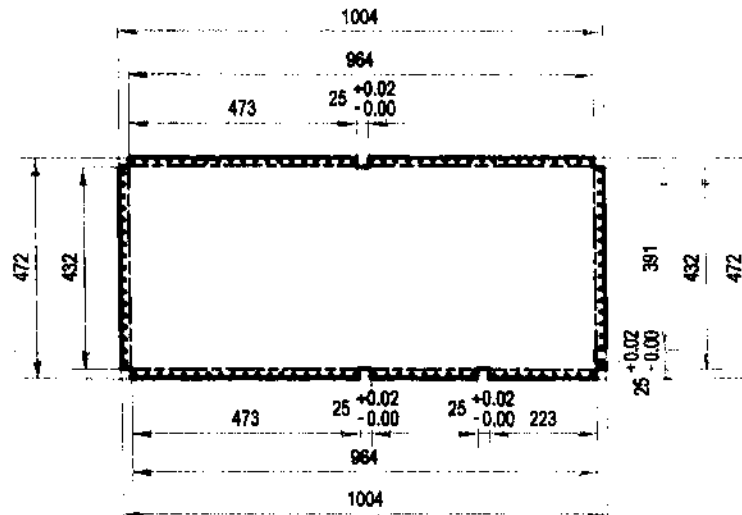

QUANTITY: 1

DETAIL A-3.2:

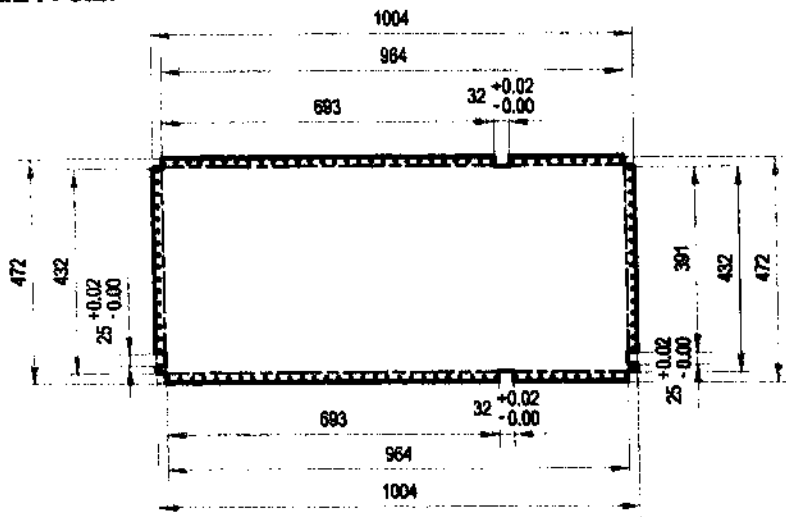

QUANTITY: 4

FLAT PATTERN: GALVANIZED SHEET GAUGE #18, PAINTED

DETAIL A-3.4:

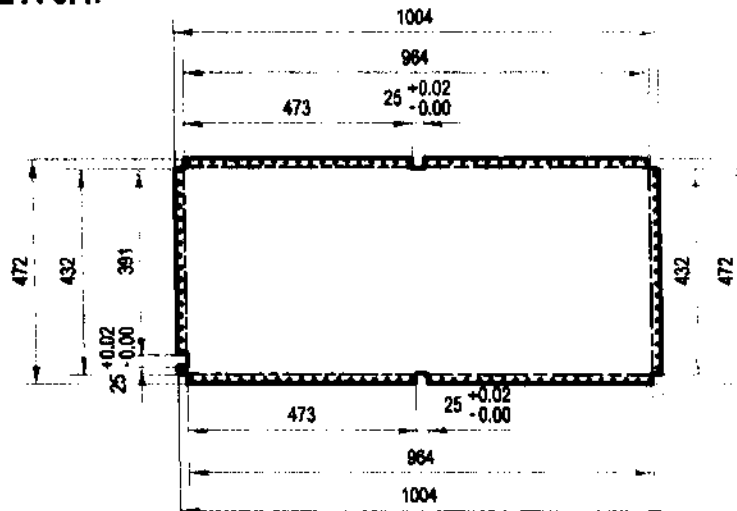

QUANTITY: 2

Use 3/16" blind rivet spaced @ 1" O.C.



TECHNICAL EDUCATION AND SKILLS DEVELOPMENT AUTHORITY

PROJECT TITLE: MOBILE TRAINING LABORATORY

DRAWN BY: JPA Scale: 1:15

Sheet No.:

DETAIL A-4.1:

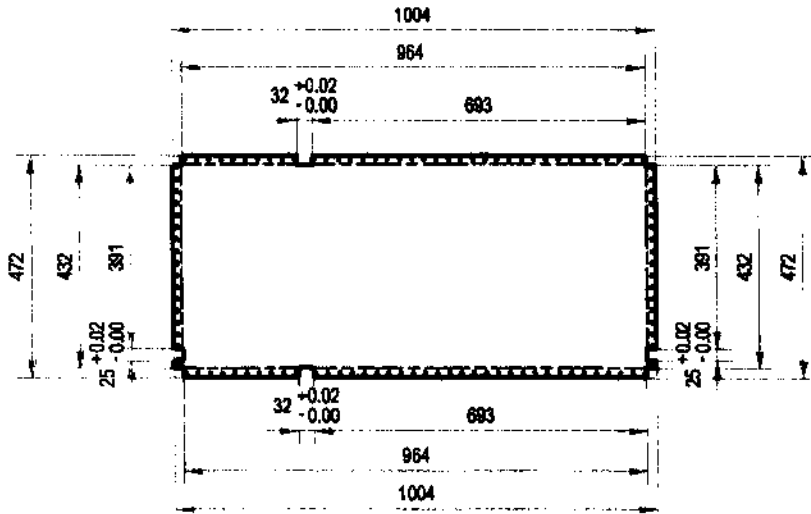

QUANTITY: 4

DETAIL A-4.2:

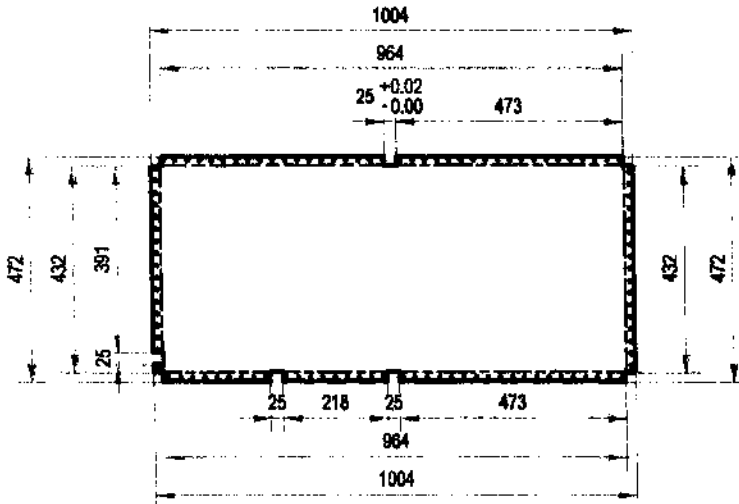

QUANTITY: 2

DETAIL A-4.3:

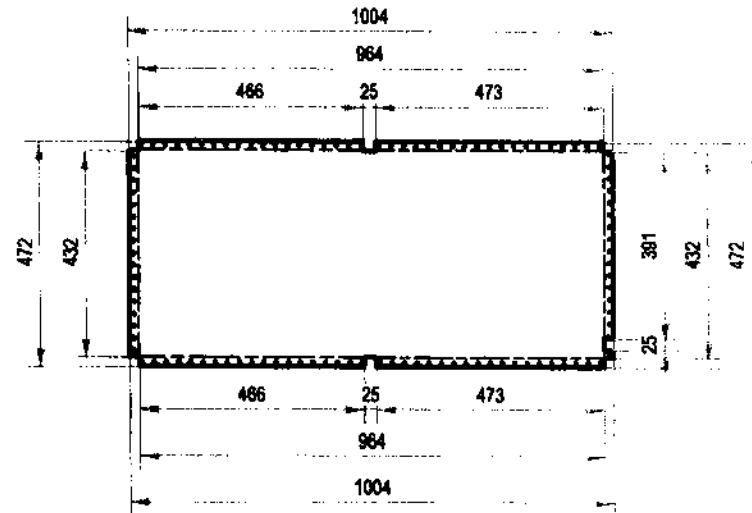

QUANTITY: 2

FLAT PATTERN: GALVANIZED SHEET GAUGE #18, PAINTED

Use 3/16" blind rivet spaced @ 1" O.C.



TECHNICAL  
EDUCATION AND  
SKILLS  
DEVELOPMENT  
AUTHORITY

PROJECT TITLE:  
**MOBILE TRAINING  
LABORATORY**



DETAIL A-5.1:

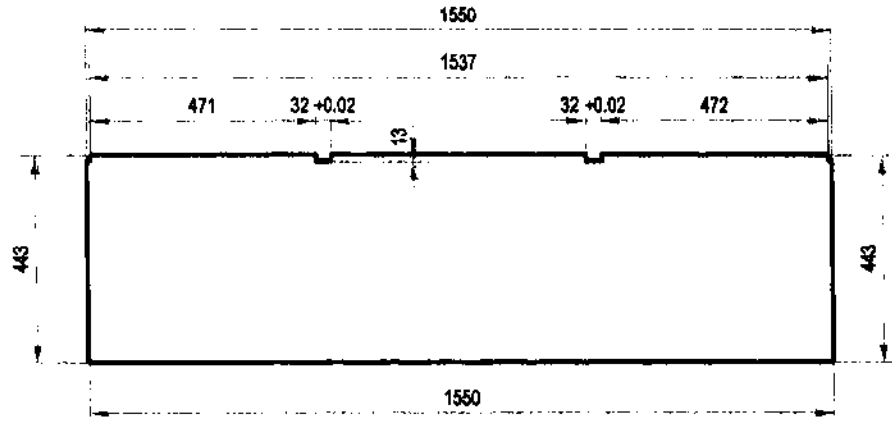

QUANTITY: 1

DETAIL A-5.3:

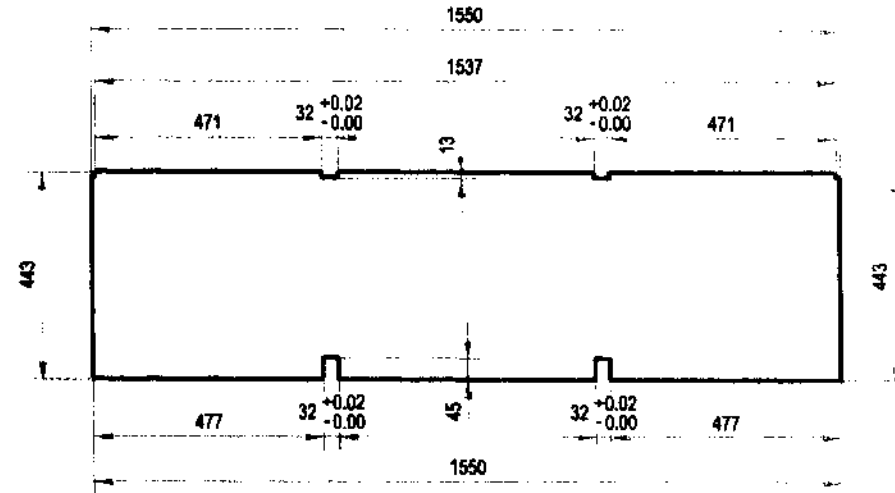

QUANTITY: 2

DETAIL A-5.2:

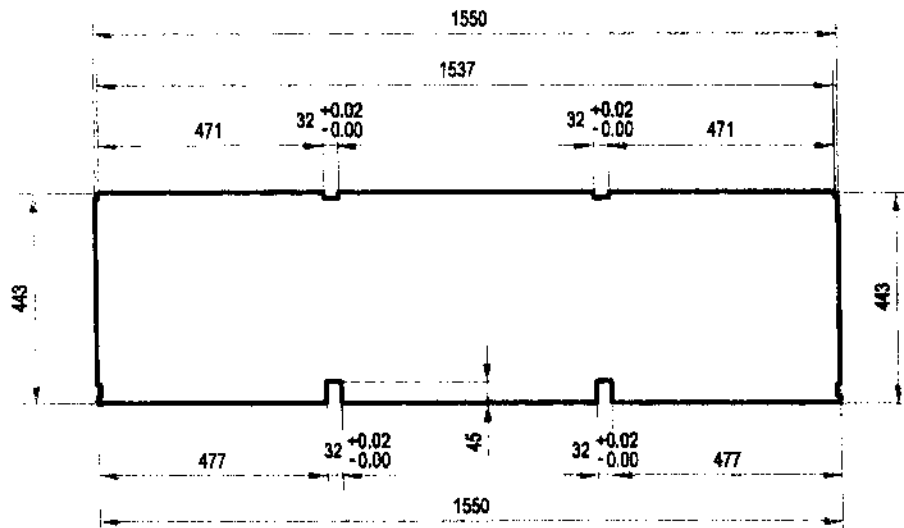

QUANTITY: 6

DETAIL A-5.4:

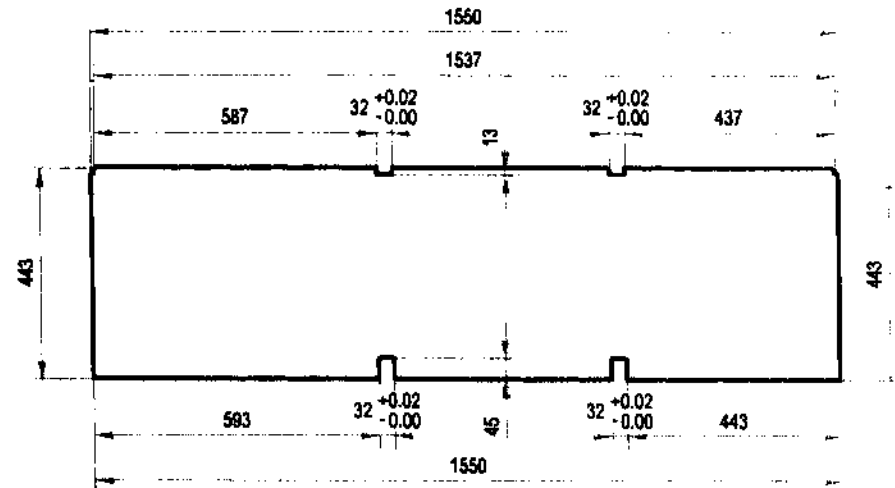

QUANTITY: 1

GALVANIZED SHEET GAUGE #18, PAINTED



TECHNICAL  
EDUCATION AND  
SKILLS  
DEVELOPMENT  
AUTHORITY

PROJECT TITLE:  
**MOBILE TRAINING  
LABORATORY**

DRAWN BY: JPA Scale: 1:15 Sheet No.: 1/

PRODUCED BY AN AUTODESK EDUCATIONAL PRODUCT

PRODUCED BY AN AUTODESK EDUCATIONAL PRODUCT

DETAIL B-1.1:

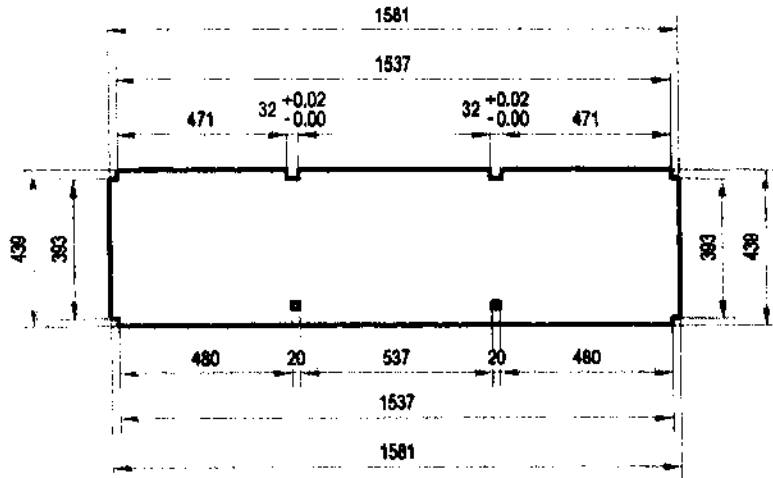

QUANTITY: 2

DETAIL B-1.3:

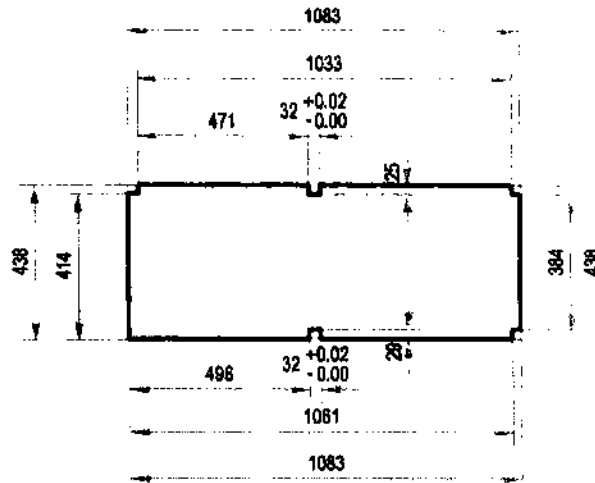

QUANTITY: 1

DETAIL B-1.2:

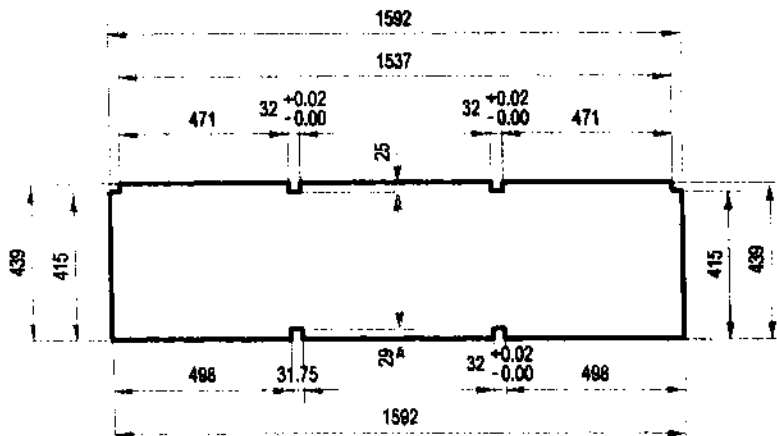

QUANTITY: 1

DETAIL B-1.4:

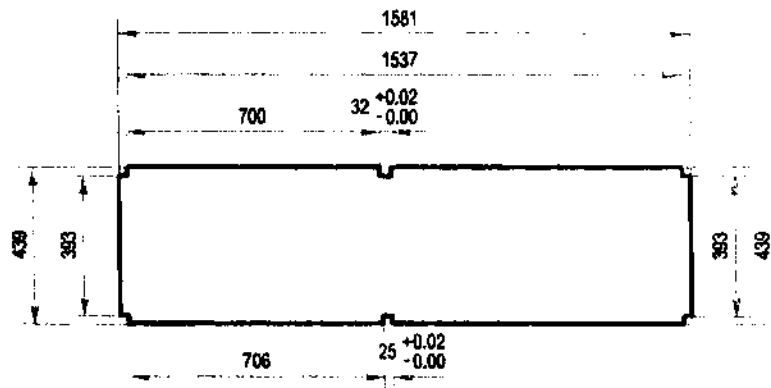

QUANTITY: 2

GALVANIZED SHEET GAUGE #18, PAINTED



TECHNICAL  
EDUCATION AND  
SKILLS  
DEVELOPMENT  
AUTHORITY

PROJECT TITLE:  
**MOBILE TRAINING  
LABORATORY**

DRAWN BY: JPA

Scale: 1:20

Sheet No.  
1/

PRODUCED BY AN AUTODESK EDUCATIONAL PRODUCT

PRODUCED BY AN AUTODESK EDUCATIONAL PRODUCT

DETAIL C-1.1:

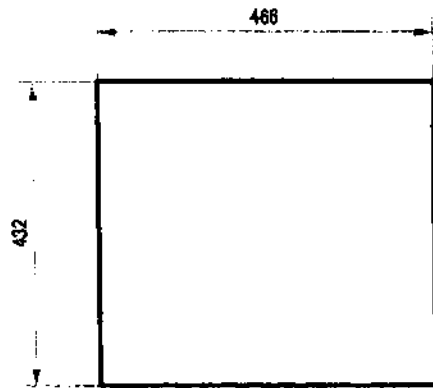

QUANTITY: 15

DETAIL C-1.3:

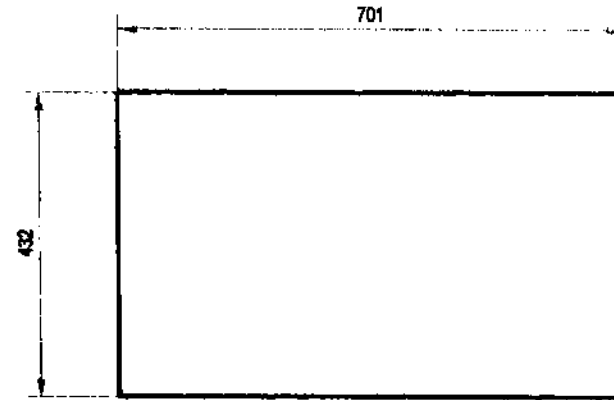

QUANTITY: 2

DETAIL C-1.2:

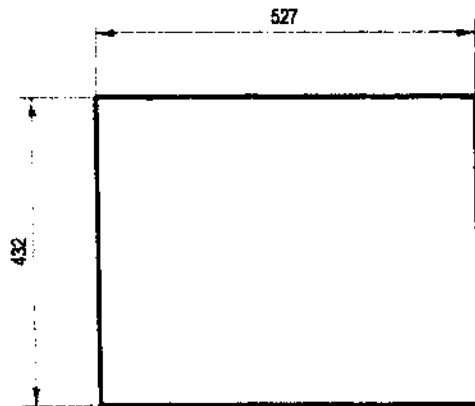

QUANTITY: 9

DETAIL D-1.1:

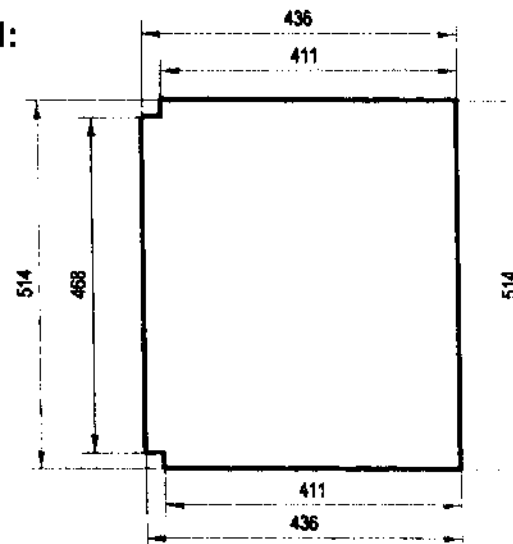

QUANTITY: 1

GALVANIZED SHEET GAUGE #18, PAINTED



TECHNICAL  
EDUCATION AND  
SKILLS  
DEVELOPMENT  
AUTHORITY

PROJECT TITLE  
**MOBILE TRAINING  
LABORATORY**

DRAWN BY: JPA	Scale: 1:10	Sheet No.: 1/
---------------	-------------	---------------

PRODUCED BY AN AUTODESK EDUCATIONAL PRODUCT

PRODUCED BY AN AUTODESK EDUCATIONAL PRODUCT

Handwritten notes: 9/11 9-11-00 and a signature.